

- R&D investment account for more than 4% of ZCC·CT sales revenue.
- 6 research platform for material and structure design research, processing research, cutting test, application technology research and development have been established.

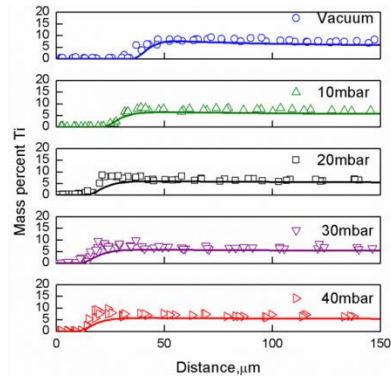

- Know how in substrate and coating

Left: Research on impact resistance of substrate

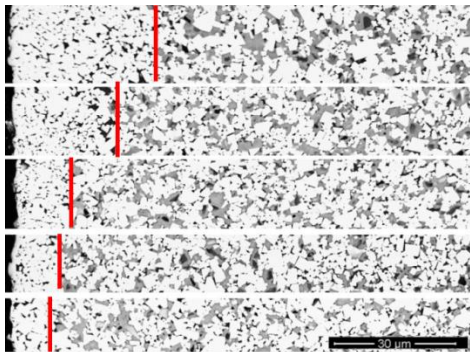
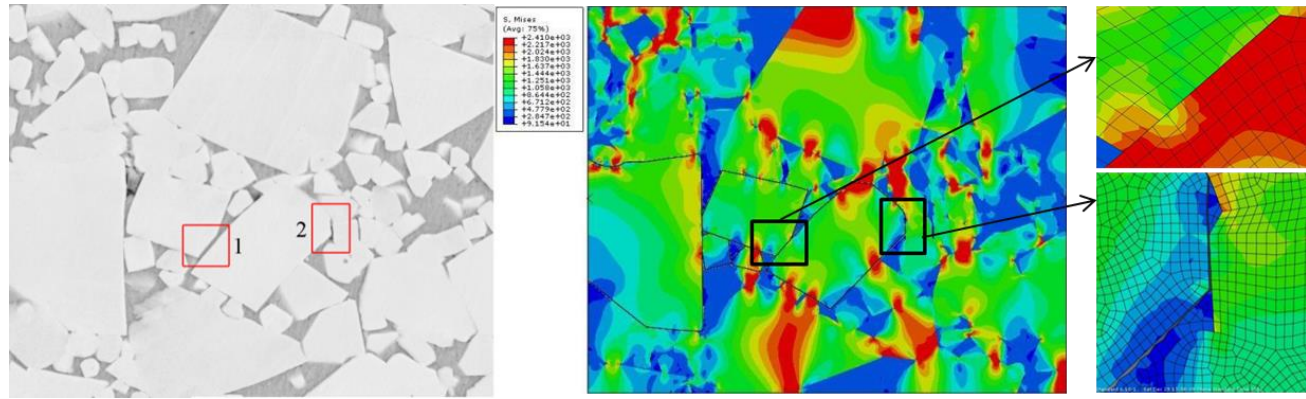

Microstructures of gradient layer at different condition

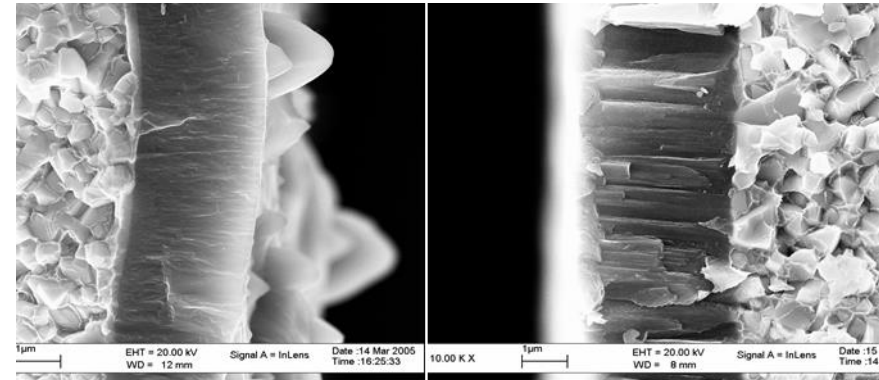

Arc evaporation

Sputtering

- **Know how in designing and simulating**
- Based on UG, CATIA, VERICUT and ADVANTEDGE FEM, a multi-functional structure design innovation platform is established for analysis, design, processing and simulation.

## APKT\* upgrade

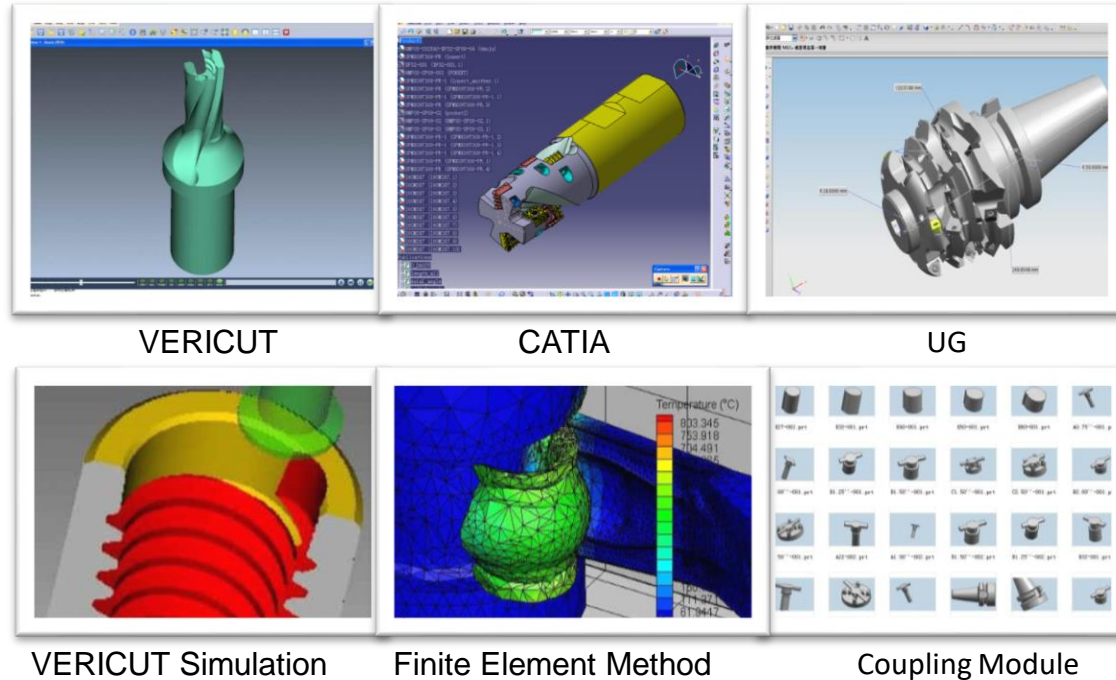
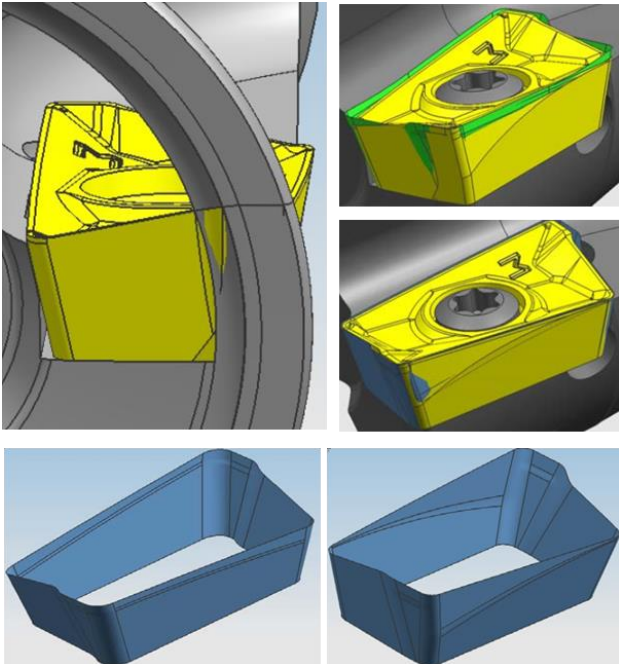

More than 40 suits of software above

- Know how in producing and application

Study on stability of cutting tool life

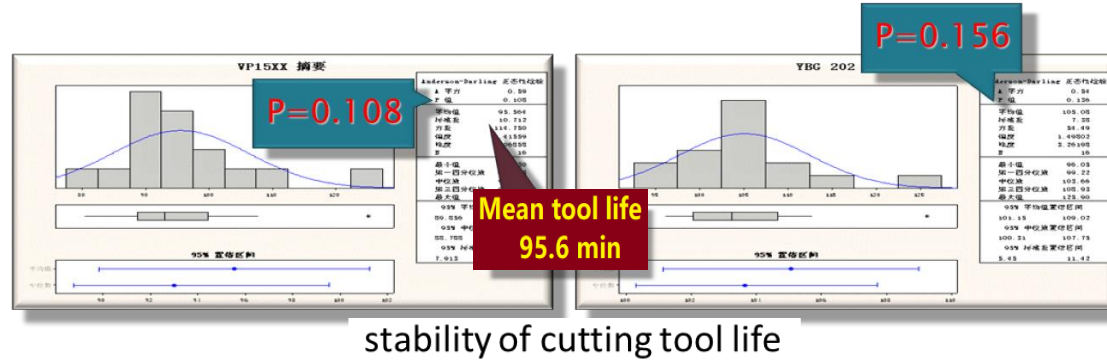

A high-speed video camera for drilling research

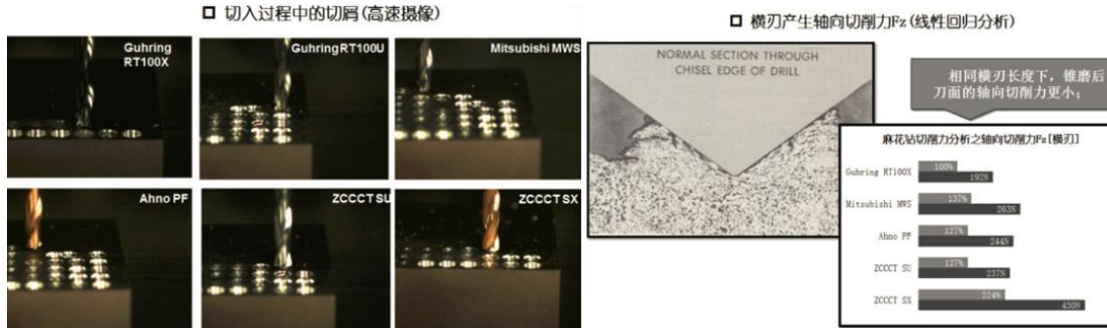

A high-speed video camera on ZTD drilling

