

模具行业 die and mould

模具工业是国民经济的基础工业，是国际上公认的关键工业。模具生产技术水平的高低是衡量一个国家产品制造水平高低的重要标志，它在很大程度上决定着产品的质量、效益和新产品的开发能力。模具的种类主要有：冲模、锻模、塑料模、压铸模、粉末冶金模、玻璃模、橡胶模、陶瓷模等。使用模具比较集中的行业主要是：汽车、家电、IT 等。

Die and Mould industry is the basic industry of national economy, an internationally recognized crucial industry. The total level of mold production technology has becoming an important indicator of a country's level of production. It largely determines the products quality, efficiency and new product development. The main types of Die and mould include stamping die, forging die, plastic die, die-casting mould, powder metallurgy mold, glass mold, rubber mold, ceramic mould, etc. The major industries applying die and mould frequently are automotive industry, household appliance, IT, etc.

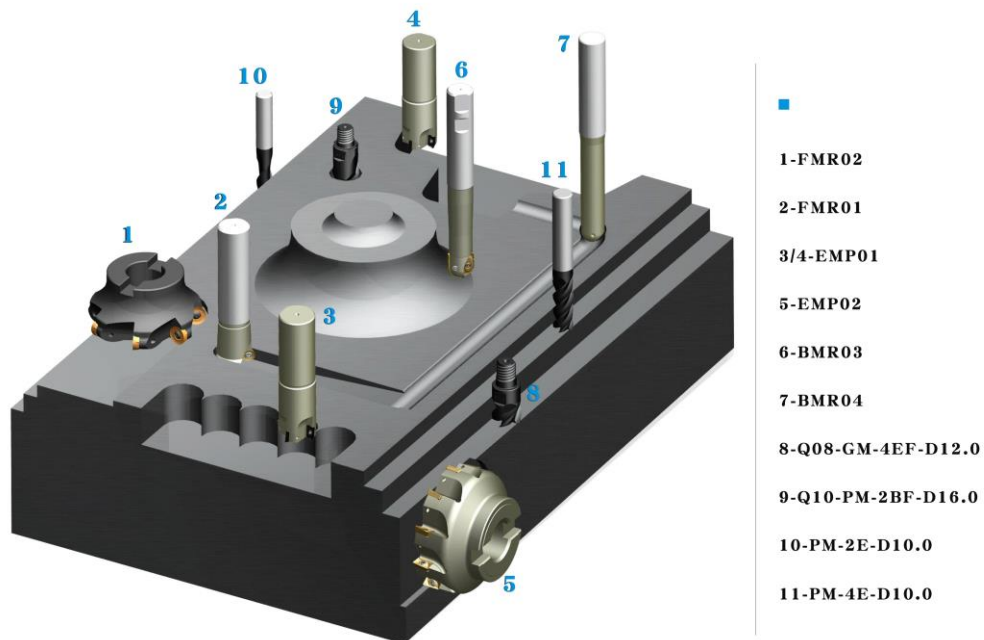

FMR 铣刀系列

FMR milling cutter series



刀片定位可靠，排屑通畅，高精度、长寿命刀体；优化的槽型和牌号实现高金属去除率切削；进给范围宽，可用于仿形加工、侧面加工、坡走加工、平面加工、螺旋插补加工、型腔加工等。

Reliable locating of insert, smooth chip evacuation, high precision, longer cutter body life; optimized geometry and grade can achieve high removal rate; wide-range of feed, can be applied in profiling, face milling, helical interpolation machining, cavity machining, etc.

EMP 方肩铣刀系列

EMP square shoulder milling cutter series:

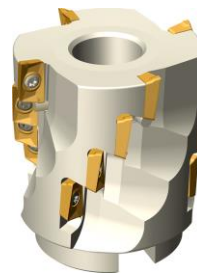

刀体、刀片组合形成双正前角，切削力小；刀片带 90 度弧线补偿，从而保证了侧面与底面垂直度，立铣效果优良；刀片有修光刃，底部表面加工质量好；安装不同槽型刀片分别用于铸铁、钢材、铝合金等材料加工；一刀多用，可进行方肩铣、槽铣、型腔铣等加工。

Double-positive angle formed by cutter body and insert, low cutting force; with 90 degree arc compensation ensuring perpendicularity of side and bottom surface, good effect of endmilling; insert with wiper, good bottom surface; different geometry insert applying in cast iron, steel, aluminum alloy and other materials respectively; one tool with multiple-functions, to be used for square shoulder milling, slot milling, cavity milling, etc.

BMR03 [仿形铣刀](#)系列

BMR03 profile milling cutter series:



可用于仿形加工、曲面加工、槽铣加工、螺旋加工等。特别适合模具复杂曲面加工及圆角清根的粗加工和半精加工

For use in profiling, surface machining, groove milling, spiral machining, etc. especially suitable for roughing and semi-finishing of complex surface and radius back chipping

BMR04 [精铣球头刀](#)系列

BMR04 series ball nose milling tool

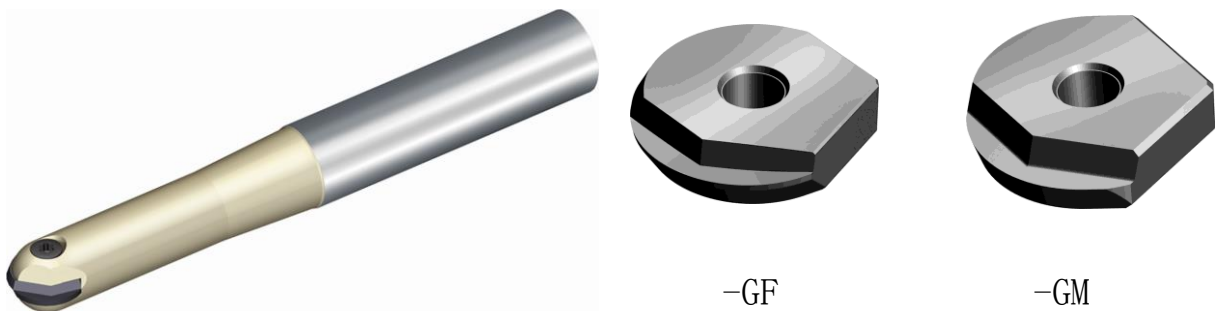

主要针对凸形、凹腔和曲面的精铣加工，常用于模具轮廓的精加工。

Mainly for convex cavity and cambered finishing, usually applied for mould and die profile finishing.

-GF 槽型刃口锋利，轮廓精度高，适用于加工工况稳定、对工件轮廓精度要求高的场合；-GM 槽型刃口强度高，适用于切深、进给较大的加工场合，有效提高切削效率。

-GM geometry with sharp edge, high profile precision, is suitable for deep depth of cutting and high feed rate occasions, can greatly improve cutting efficiency.

[可换头模块式铣刀](#)系列

Interchangeable cutter head modular series

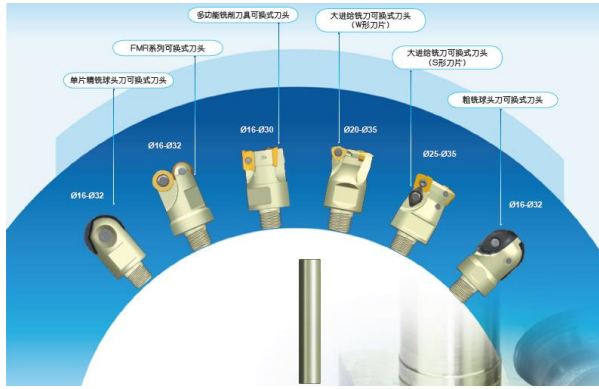

图片的文字翻译

单片精铣球头刀可换式刀头 single ball-nose insert interchangeable cutter head for finish milling

FMR 系列可换式刀头 FMR series interchangeable cutter head

多功能铣削刀具可换式刀头 Multipurpose tool with interchangeable cutter head

大进给铣刀可换式刀头 (W 形刀片) high feed milling cutter with interchangeable cutter head(W shape insert)

大进给铣刀可换式刀头 (S 形刀片) high feed milling cutter with interchangeable cutter head(S shape insert)

粗铣球头刀可换式刀头 ball-nose rough milling cutter with interchangeable cutter head

使用一支刀杆完成从粗加工到精加工的多道工序，真正意义上实现一刀多用。可实现在机床上快速更换，减少切削加工的辅助时间，大幅提高生产效率。可转位可换头系列和整体硬质合金可换头系列共用刀杆，满足面铣、槽铣、方肩铣、仿形铣、坡走铣和螺旋插补铣等各种加工场合。

With only one toolholder can realize operations from roughing to finishing. Quick tool head exchange on the machine reduces cutting time and greatly improves production efficiency. Solid carbide interchangeable cutter head series shared a toolholder with indexable interchangeable series, can well meet the demands ranging from roughing to finishing operations in face milling, slot milling, square milling, profile milling, ramping, helical interpolation.

GM [整体立铣刀](#)系列

GM solid carbide endmill series





槽型经过严格控制，能够更好的改善切削流动和卷曲，以及降低切削力。高稳定性的刃口处理和高刚性的结构设计，刀具能获得更大的每齿进给量 FZ ，极大的提高金属去除率和加工效率。在高效率的加工条件下，也具有良好的耐磨性和抗崩性能。

Geometry under strictly control can provide better improve chips flow and chip curling with lower cutting force. High stability edges treatment and high rigidity structure design ensure higher feed rate per tooth, greatly improve high metal removal rate and working efficiency. Under high-efficiency condition, this type of tool still has excellent wear-resistance and chipping resistance, suitable for finishing and semi-finishing.

<http://www.zccct.com>