

Profile milling tools

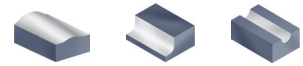



BMR02 P M K



Specification of tools

Type		Dimensions(inch)					
		ØD	R	ød	L	L1	Z (Number of teeth)
BMR02	-12-G0.472" -S	0.472	0.236	0.625	4.50	1.50	2
	-12-G0.472" -M	0.472	0.236	0.625	5.00	2.00	2
	-12-G0.472" -L	0.472	0.236	0.625	6.00	2.00	2
	-16-G0.630" -S	0.630	0.315	0.750	6.00	1.75	2
	-16-G0.630" -M	0.630	0.315	0.750	6.50	2.50	2
	-16-G0.630" -L	0.630	0.315	0.750	8.00	2.50	2
	-20-G0.787" -S	0.787	0.394	1.000	6.50	2.50	2
	-20-G0.787" -M	0.787	0.394	1.000	8.00	3.00	2
	-20-G0.787" -L	0.787	0.394	1.000	9.50	3.00	2

Spare parts

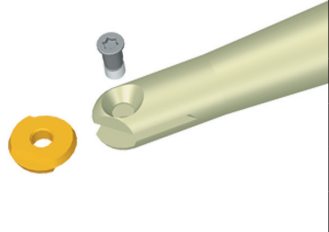
Diameter ØD	Insert specification	Screw	Wrench	Sketch of installation
				
Ø0.472"	ROHX1203	I70M4×10TT	WT15IS	
Ø0.630"	ROHX1604	I70M5×12TT	WT20IS	
Ø0.787"	ROHX2005	I70M5×16TT	WT20IS	

Selection of inserts

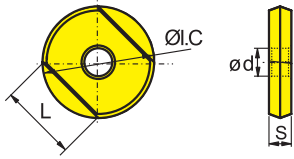

😊 Good working conditions 😐 General working conditions 😞 Adverse working conditions

Workpiece material	P Steel	M Stainless steel	K Cast iron	N Ferrite materials	S Heat-resistant steel
P Steel	😊	😊	😊	😊	😊
M Stainless steel	😊	😊	😊	😊	😊
K Cast iron	😊	😊	😊	😊	😊
N Ferrite materials	😊	😊	😊	😊	😊
S Heat-resistant steel	😊	😊	😊	😊	😊

Insert shape	Type	Dimensions(inch)				Coated grade						Uncoated grade		Adaptable tool holders	
		ØI.C	L	S	ød	YBC301	YBC302	YBM251	YBM253	YBG102	YBG205	YBG252	YBG302		YD101
	ROHX1203	0.472	0.335	0.118	0.157							●			Ø0.472"
	ROHX1604	0.630	0.445	0.157	0.197							●			Ø0.630"
	ROHX2005	0.787	0.555	0.197	0.197							●			Ø0.787"

● Always stock available ○ Produce according to order

Recommended cutting parameters

Workpiece material	Hardness HB	Insert grade	Cutting parameters	Diameter		
				Ø0.472"	Ø0.63"	Ø0.787"
P	Carbon steel	YBG252	V(SFPM)	300~650	300~650	300~650
			fz(IPT)	0.006~0.01	0.008~0.012	0.008~0.012
			a _{pmax} (inch)	0.032	0.04	0.05
			a _{emax} (inch)	0.032	0.04	0.05
	Alloy steel		V(SFPM)	260~600	260~600	260~600
			fz(IPT)	0.006~0.01	0.008~0.012	0.008~0.012
			a _{pmax} (inch)	0.032	0.04	0.05
			a _{emax} (inch)	0.032	0.04	0.05
	Hardened steel		V(SFPM)	200~300	200~300	200~300
			fz(IPT)	0.006~0.01	0.008~0.012	0.008~0.012
			a _{pmax} (inch)	0.016	0.02	0.024
			a _{emax} (inch)	0.016	0.02	0.024
M	Stainless steel	V(SFPM)	230~150	230~150	230~150	
		fz(IPT)	0.004~0.008	0.004~0.01	0.004~0.01	
		a _{pmax} (inch)	0.024	0.032	0.04	
		a _{emax} (inch)	0.024	0.032	0.04	
K	Cast iron	V(SFPM)	500~1000	500~1000	500~1000	
		fz(IPT)	0.008~0.012	0.01~0.014	0.01~0.014	
		a _{pmax} (inch)	0.04	0.06	0.07	
		a _{emax} (inch)	0.04	0.06	0.07	



Profile milling tools



BMR04



Straight shank with straight neck

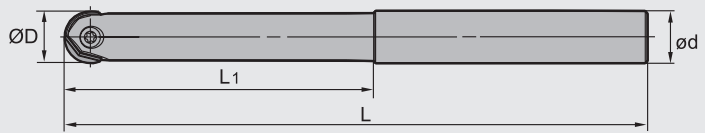

Specification of tools

Type		Dimensions(inch)				
		ØD	ød	L1	L	Z (Number of teeth)
BMR04	-0.625"-G0.625"-M	0.625	0.625	2.0	4.5	2
	-0.625"-G0.625"-L	0.625	0.625	3.0	6.5	2
	-0.75"-G0.75"-M	0.750	0.750	2.5	5.0	2
	-0.75"-G0.75"-L	0.750	0.750	3.5	7.0	2
	-1.00"-G1.00"-M	1.000	1.000	2.5	5.5	2
	-1.00"-G1.00"-L	1.000	1.000	3.5	8.0	2
	-1.00"-G1.00"-XL	1.000	1.000	5.0	10.0	2
	-1.25"-G1.25"-M	1.250	1.250	3.0	6.0	2
	-1.25"-G1.25"-L	1.250	1.250	4.0	9.0	2
	-1.25"-G1.25"-XL	1.250	1.250	5.0	12.0	2

Spare parts

Diameter ØD	Insert specification	Insert screw	Wrench	Sketch of installation
Ø0.625"	ZOHX5-□□	I70M5×12TT	WT15IP	
Ø0.75"	ZOHX6-□□	I70M5×16TT	WT20IP	
Ø1.00"	ZOHX8-□□	I70M6×20TT	WT20IP	
Ø1.25"	ZOHX10-□□	I70M8×25TT	WT30IT	

Selection of inserts

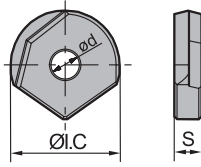

😊 Good working conditions 😐 General working conditions 😞 Adverse working conditions

Workpiece material	P Steel	M Stainless steel	K Cast iron	N Ferrite materials	S Heat-resistant steel
P Steel	😊😊😊	😊😊😊	😊😊😊	😊😊😊	😊😊😊
M Stainless steel	😊😊😊	😊😊😊	😊😊😊	😊😊😊	😊😊😊
K Cast iron	😊😊😊	😊😊😊	😊😊😊	😊😊😊	😊😊😊
N Ferrite materials	😊😊😊	😊😊😊	😊😊😊	😊😊😊	😊😊😊
S Heat-resistant steel	😊😊😊	😊😊😊	😊😊😊	😊😊😊	😊😊😊

Insert shape	Type	Dimensions(inch)			Coated grade						Uncoated grade	Adaptable tool holders		
		ØI.C	ød	S	YBC302	YBM251	YBM253	YBG102	YBG205	YBG252	YBG302		YD101	YD201
	ZOHX5-GF	0.625	0.197	0.157						●				D0.625"
	ZOHX6-GF	0.750	0.197	0.197						●				D0.75"
	ZOHX8-GF	1.000	0.236	0.236						●				D1.00"
	ZOHX10-GF	1.250	0.315	0.276						●				D1.25"
	ZOHX5-GM	0.625	0.197	0.157						●				D0.625"
	ZOHX6-GM	0.750	0.197	0.197						●				D0.75"
	ZOHX8-GM	1.000	0.236	0.236						●				D1.00"
	ZOHX10-GM	1.250	0.315	0.276						●				D1.25"

● Always stock available ○ Produce according to order

D

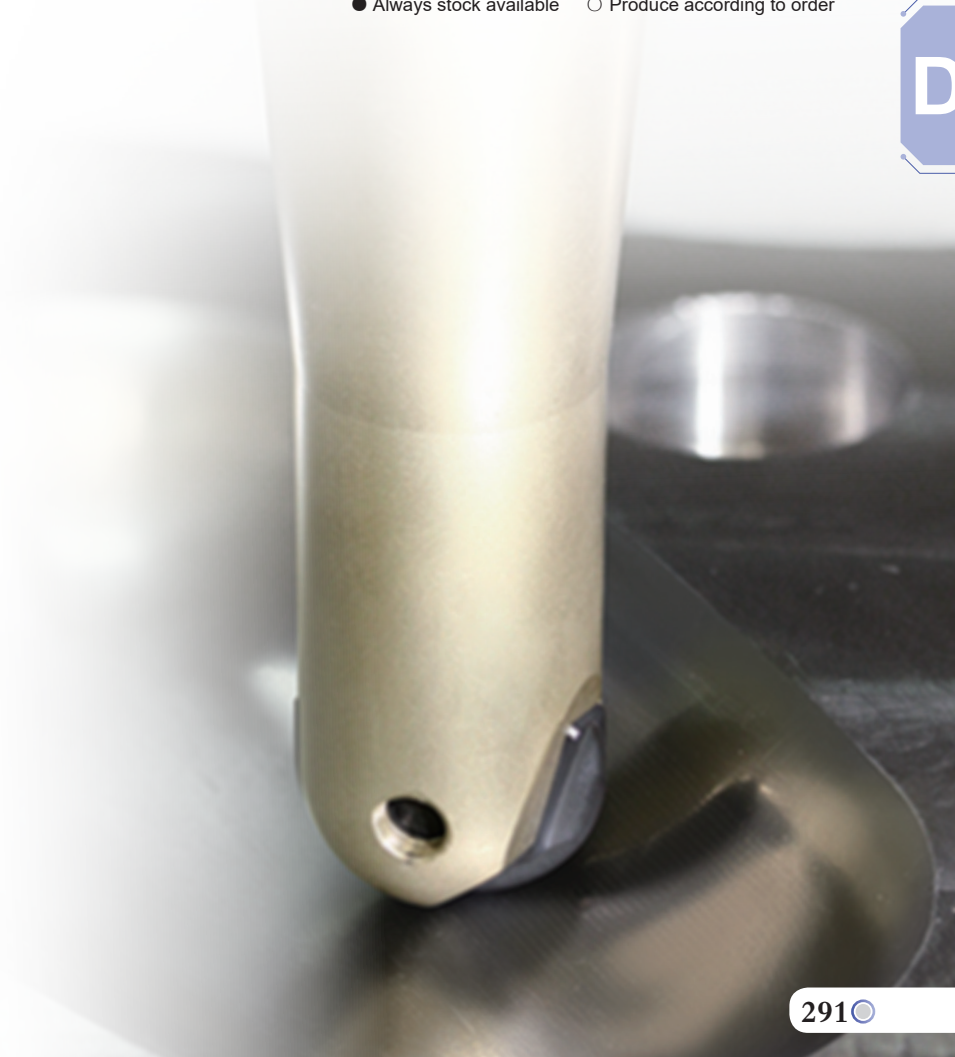

Calculation of cutting speed for BMR02/04 series ball nose end mills

1. When the tool axial line is vertical to the surface being machined,

$$N = \frac{1000 V_c}{\pi D_c} \text{ (r/min)}$$

$$D_c = 2\sqrt{a_p(D - a_p)}$$

N: rotating speed
 Vc: actual cutting speed
 Dc: effective cutting diameter
 D: tool nominal diameter
 ap: axial cutting depth

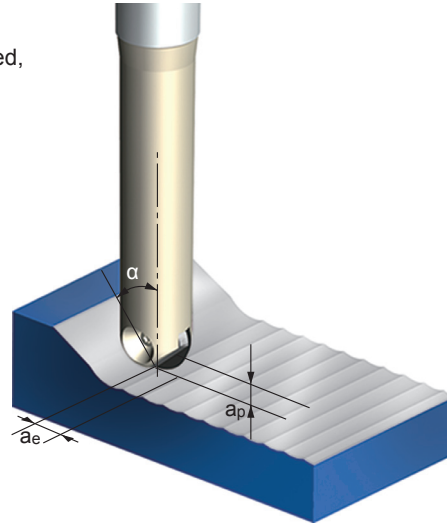

2. When there is an inclined angle between the tool axial line and the surface being machined, the recommended cutting speed should be multiplied by a factor in the table below to obtain the cutting speed used for programming.

Diameter (inch)		Ø0.625		Ø0.75		Ø1.00		Ø1.25	
Cutting depth ap (inch)		0.008	0.020	0.020	0.039	0.020	0.039	0.020	0.060
Inclined angle α	15°	1.00	1.00	1.00	1.02	1.00	1.01	1.00	1.00
	30°	1.05	1.01	1.02	1.04	1.03	1.04	1.04	1.00
	45°	1.18	1.10	1.12	1.06	1.14	1.08	1.16	1.06
	60°	1.47	1.30	1.34	1.21	1.38	1.25	1.43	1.22
	75°	2.14	1.73	1.83	1.53	1.93	1.62	2.04	1.55
	90°	4.48	2.87	3.20	2.29	3.57	2.55	4.03	2.37

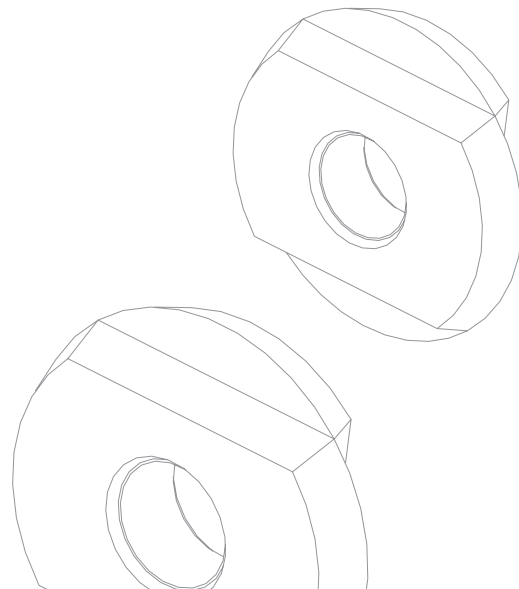
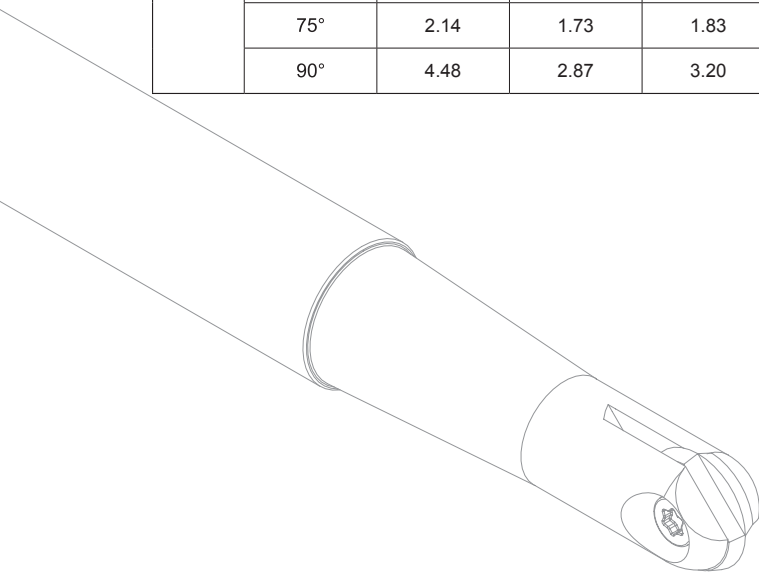

Recommended cutting parameters

Workpiece material	Hardness HB	Insert grade	Cutting parameters	Diameter				
				Ø0.625	Ø0.75	Ø1.00	Ø1.25	
P	Carbon steel	YBG252	V(SFPM)	300~650	300~650	300~650	300~650	
			fz(IPT)	0.008~0.012	0.008~0.012	0.01~0.014	0.01~0.014	
			a _{pmax} (inch)	0.04	0.05	0.06	0.08	
			a _{emax} (inch)	0.04	0.05	0.06	0.08	
	Alloy steel		HB180~280	V(SFPM)	260~600	260~600	260~600	260~600
				fz(IPT)	0.008~0.012	0.008~0.012	0.01~0.014	0.01~0.014
				a _{pmax} (inch)	0.04	0.05	0.06	0.08
				a _{emax} (inch)	0.04	0.05	0.06	0.08
	Hardened steel		HRC55~65	V(SFPM)	200~300	200~300	200~300	200~300
				fz(IPT)	0.008~0.012	0.008~0.012	0.01~0.014	0.01~0.014
				a _{pmax} (inch)	0.02	0.024	0.032	0.04
				a _{emax} (inch)	0.02	0.024	0.032	0.04
M	Stainless steel	YBG252	V(SFPM)	230~500	230~500	230~500	230~500	
			fz(IPT)	0.004~0.01	0.004~0.01	0.008~0.012	0.008~0.012	
			a _{pmax} (inch)	0.032	0.04	0.05	0.06	
			a _{emax} (inch)	0.032	0.04	0.05	0.06	
K	Cast iron		YBG252	V(SFPM)	500~1000	500~1000	500~1000	500~1000
				fz(IPT)	0.01~0.014	0.01~0.014	0.012~0.016	0.012~0.016
				a _{pmax} (inch)	0.06	0.07	0.08	0.1
				a _{emax} (inch)	0.06	0.07	0.08	0.1



High feed milling cutters

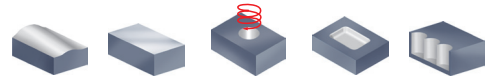

XMR01 P M K S



S-type insert, straight shank

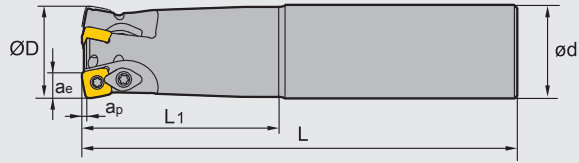

Specification of tools

Type		Dimensions(inch)						
		ØD	ød	L ₁	L	a _p max	a _e max	Z (Number of teeth)
XMR01	-0.75"-G0.75"-SD06-02C	0.75	0.75	2.50	6	0.031	0.196	2
	-0.75"-G0.75"-SD06-02CL	0.75	0.75	4.00	7	0.031	0.196	2
	-0.75"-G0.75"-SD06-02CXL	0.75	0.75	5.00	10	0.031	0.196	2
	-1.00"-G1.00"-SD06-03C	1.00	1.00	3.50	7	0.031	0.196	3
	-1.00"-G1.00"-SD06-03CL	1.00	1.00	4.50	8	0.031	0.196	3
	-1.00"-G1.00"-SD06-03CXL	1.00	1.00	5.00	11	0.031	0.196	3
	-1.00"-G1.00"-SD09-02C	1.00	1.00	3.50	7	0.055	0.297	2
	-1.00"-G1.00"-SD09-02CL	1.00	1.00	4.50	8	0.055	0.297	2
	-1.00"-G1.00"-SD09-02CXL	1.00	1.00	7.00	12	0.055	0.297	2
	-1.25"-G1.25"-SD09-03C	1.25	1.25	3.50	8	0.055	0.297	3
	-1.25"-G1.25"-SD09-03CL	1.25	1.25	4.50	8	0.055	0.297	3
	-1.25"-G1.25"-SD09-03CXL	1.25	1.25	7.00	12	0.055	0.297	3
	-1.25"-G1.25"-SD12-02C	1.25	1.25	3.50	8	0.071	0.380	2
	-1.25"-G1.25"-SD12-02CL	1.25	1.25	4.50	8	0.071	0.380	2
	-1.25"-G1.25"-SD12-02CXL	1.25	1.25	7.00	12	0.071	0.380	2
	-1.50"-G1.50"-SD12-03C	1.50	1.50	3.50	8	0.071	0.380	3
	-1.50"-G1.50"-SD12-03CL	1.50	1.50	5.00	11	0.071	0.380	3
	-1.50"-G1.50"-SD12-03CXL	1.50	1.50	7.00	12	0.071	0.380	3
	-1.50"-G1.50"-SD15-02C	1.50	1.50	4.50	8	0.087	0.508	2
	-1.50"-G1.50"-SD15-02CL	1.50	1.50	5.00	11	0.087	0.508	2
-1.50"-G1.50"-SD15-02CXL	1.50	1.50	7.00	12	0.087	0.508	2	
-1.75"-G1.50"-SD15-02C	1.75	1.50	4.50	10	0.087	0.508	2	

XMR01-0.75"-G0.75"-SD06-02CL/XL

Number of teeth ——— Extra long series
Coolant through ——— Long series

Spare parts

Tool type	Insert screw	Wedge screw	Clamp	Insert wrench	Wedge wrench	Sketch of installation
XMR01□□-SD06□□	I60M2.2×5.5	--	--	WT07IP	---	
XMR01□□-SD09□□	I60M3.5×08TT	I60M4×8.4	WD-204	WT10IP	WT15IP	
XMR01□□-SD12□□	I60M4×8.4	I60M4×8.4	WD-204	WT15IP	WT15IP	
XMR01□□-SD15□□	I60M5×13	I60M5×13	WD-208	WT20IP	WT20IP	

High feed milling cutters

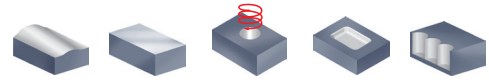

XMR01 P M K S



S-type insert, arbor mounting

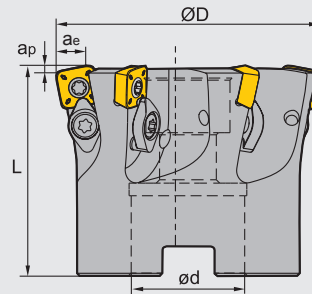

Specification of tools

Type		Dimensions (inch)					
		ØD	ød	L	apmax	ae max	Z (Number of teeth)
XMR01	-2.00"-A0.75"-SD06-07C	2.00	0.75	1.75	0.031	0.196	7
	-2.50"-A0.75"-SD06-10C	2.50	0.75	1.75	0.031	0.196	10
	-2.50"-A1.00"-SD06-10C	2.50	1.00	2.00	0.031	0.196	10
	-2.00"-A0.75"-SD09-05C	2.00	0.75	1.75	0.055	0.297	5
	-2.50"-A0.75"-SD09-07C	2.50	0.75	1.75	0.055	0.297	7
	-2.50"-A1.00"-SD09-07C	2.50	1.00	2.00	0.055	0.297	7
	-2.50"-A0.75"-SD12-05C	2.50	0.75	1.75	0.071	0.380	5
	-2.00"-A0.75"-SD12-05C(L=2")	2.00	0.75	2.00	0.071	0.380	5
	-2.50"-A1.00"-SD12-05C	2.50	1.00	2.00	0.071	0.380	5
	-3.00"-A1.00"-SD12-06C	3.00	1.00	2.00	0.071	0.380	6
	-3.00"-A1.25"-SD12-06C	3.00	1.25	2.00	0.071	0.380	6
	-4.00"-B1.50"-SD12-08	4.00	1.50	2.50	0.071	0.380	8
	-3.00"-A1.00"-SD15-05C	3.00	1.00	2.00	0.087	0.508	5
	-3.00"-A1.25"-SD15-05C	3.00	1.25	2.00	0.087	0.508	5
	-4.00"-B1.50"-SD15-07	4.00	1.50	2.50	0.087	0.508	7
	-5.00"-B1.50"-SD15-09	5.00	1.50	2.50	0.087	0.508	9
-6.00"-B2.00"-SD15-12	6.00	2.00	2.50	0.087	0.508	12	

Spare parts

Tool type	Insert screw	Wedge screw	Clamp	Insert wrench	Wedge wrench	Sketch of installation
XMR01□□-SD06□□	I60M2.2×5.5	--	--	WT07IP	---	
XMR01□□-SD09□□	I60M3.5×08TT	I60M4×8.4	WD-204	WT10IP	WT15IP	
XMR01□□-SD12□□	I60M4×8.4	I60M4×8.4	WD-204	WT15IP	WT15IP	
XMR01□□-SD15□□	I60M5×13	I60M5×13	WD-208	WT20IP	WT20IP	

Selection of inserts

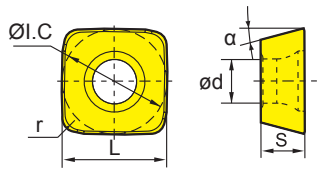

😊 Good working conditions 🙄 General working conditions 😞 Adverse working conditions

Workpiece material	P Steel	M Stainless steel	K Cast iron	N Ferrite materials	S Heat-resistant steel
P Steel	😊	😊	😊	😊	😊
M Stainless steel	😊	😊	😊	😊	😊
K Cast iron	😊	😊	😊	😊	😊
N Ferrite materials	😊	😊	😊	😊	😊
S Heat-resistant steel	😊	😊	😊	😊	😊

Insert shape	Type	Dimensions(inch)						Coated grade										Uncoated grade			
		α	L	r	S	ød	ØI.C	YBC302	YBM251	YBM253	YBM351	YBG102	YBG202	YBG212	YBG205	YBG302	YBS203	YBS303	YD101	YD201	
	SDMT06T208-DM	15°	0.250	0.031	0.101	0.102	0.250	●				●				○					
	SDMT09T312-DM	15°	0.375	0.047	0.156	0.157	0.375	●				●				○					
	SDMT120412-DM	15°	0.500	0.047	0.187	0.173	0.500	●				●				○					
	SDMT150520-DM	15°	0.625	0.079	0.219	0.220	0.625	●				●				○					
	SDMT06T208-PM	15°	0.250	0.031	0.101	0.102	0.250	●		○					●						
	SDMT09T312-PM	15°	0.375	0.047	0.156	0.157	0.375	●		●					●						
	SDMT120412-PM	15°	0.500	0.047	0.187	0.173	0.500	●		●					●						
	SDMT150520-PM	15°	0.625	0.079	0.219	0.220	0.625	●		●					●						
	SDMT09T312-NM	15°	0.500	0.047	0.187	0.173	0.500			●				●			○	○			
	SDMT120412-NM	15°	0.375	0.047	0.156	0.157	0.375							●			○	○			

● Always stock available ○ Produce according to order

Chipbreaker introduction:

- PM chipbreaker is more suitable for machining with power shortage and for relatively adhesive materials, such as stainless steel.
- DM chipbreaker is relatively suitable for machining of hard materials such as hardened steel, cast iron, etc.
- NM The reinforcement on the cutting edges of the NM chipbreaker has high wear resistance which is more suitable for milling of hard-to-cut materials.

High feed milling cutters

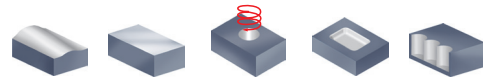

XMR01 **P** **M** **K**



W-type insert, straight shank

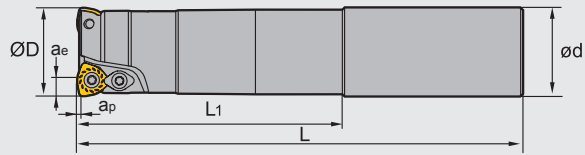

Specification of tools

Type		Dimensions(inch)						
		ØD	ap	ae	L ₁	L	ød	Z (Number of teeth)
XMR01	-0.75" -G0.75" -WP05-02-M	0.75	0.059	0.150	1.75	5.00	0.75	2
	-0.75" -G0.75" -WP05-02-L	0.75	0.059	0.150	3.75	7.00	0.75	2
	-0.75" -G0.75" -WP05-02-XL	0.75	0.059	0.150	4.75	10.00	0.75	2
	-1.00" -G1.00" -WP06-02-M	1.00	0.059	0.171	2.25	5.50	1.00	2
	-1.00" -G1.00" -WP06-02-L	1.00	0.059	0.171	4.75	8.00	1.00	2
	-1.00" -G1.00" -WP06-02-XL	1.00	0.059	0.171	4.75	12.00	1.00	2
	-1.25" -G1.25" -WP06-02-M	1.25	0.059	0.171	2.75	6.00	1.25	2
	-1.25" -G1.25" -WP06-02-L	1.25	0.059	0.171	4.75	8.00	1.25	2
	-1.25" -G1.25" -WP06-02-XL	1.25	0.059	0.171	7.25	12.00	1.25	2
	-1.50" -G1.25" -WP06-03-M	1.50	0.059	0.171	2.00	6.00	1.25	3
	-1.50" -G1.50" -WP06-03-L	1.50	0.059	0.171	2.00	10.00	1.50	3
	-1.50" -G1.25" -WP06-03-XL	1.50	0.059	0.171	2.00	12.00	1.25	3
	-1.50" -G1.25" -WP08-02-M	1.50	0.059	0.223	2.00	6.00	1.25	2
	-1.50" -G1.25" -WP08-02-L	1.50	0.059	0.223	2.00	10.00	1.25	2
	-1.50" -G1.25" -WP08-02-XL	1.50	0.059	0.223	2.00	12.00	1.25	2
	-2.00" -G1.50" -WP09-02-M	2.00	0.118	0.268	2.15	6.00	1.50	2
-2.00" -G1.50" -WP09-02-L	2.00	0.118	0.268	2.15	10.00	1.50	2	

Spare parts

Adaptable tool holders	Insert screw	Clamp	Wrench	Sketch of installation
XMR01□□-WP05□□	I60M3.5×6.5	--	WT10IP	
XMR01□□-WP06□□	I60M4×8.4		WT15IP	
XMR01□□-WP08□□	I60M5×13	WD-208	WT20IT	
XMR01□□-WP09□□				

High feed milling cutters

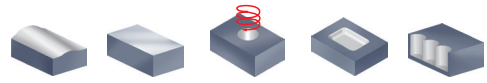

XMR01 P M K

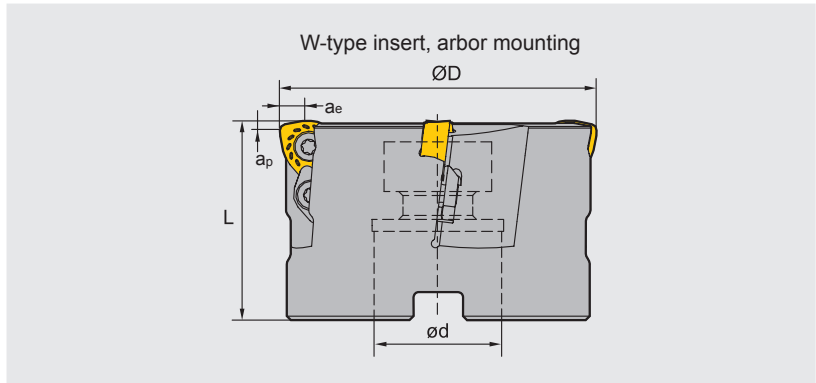

Specification of tools

Type		Dimensions(inch)					
		ØD	ap	ae	L	ød	Z (Number of teeth)
XMR01	-2.00"-A0.75"-WP06-05	2.00	0.059	0.171	2.000	0.750	5
	-2.00"-A0.75"-WP08-04	2.00	0.059	0.223	2.000	0.750	4
	-2.00"-A0.75"-WP06-04	2.00	0.059	0.171	2.000	0.750	4
	-2.50"-A0.75"-WP08-04	2.50	0.059	0.223	2.000	0.750	4
	-2.50"-A1.00"-WP08-04	2.50	0.059	0.223	2.000	1.000	4
	-2.50"-A0.75"-WP09-03	2.50	0.118	0.268	2.000	0.750	3
	-3.00"-A1.25"-WP08-04	3.00	0.059	0.223	2.500	1.250	4
	-3.00"-A1.25"-WP09-04	3.00	0.118	0.268	2.500	1.250	4
	-4.00"-B1.25"-WP08-05	4.00	0.059	0.223	2.500	1.250	5
	-4.00"-B1.25"-WP09-05	4.00	0.118	0.268	2.500	1.250	5

Spare parts

Tool type	Insert screw	Clamp	Wrench	Sketch of installation
XMR01□□-WP06□□	I60M4×8.4	--	WT15IS	
XMR01□□-WP08□□	I60M5×13	WD-208	WT20IT	
XMR01□□-WP09□□	I60M5×13	WD-208	WT20IT	

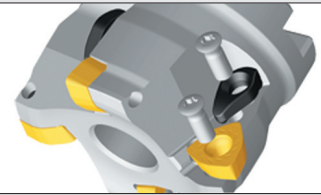

Selection of inserts

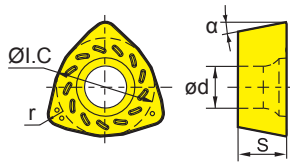

😊 Good working conditions 🙄 General working conditions 😞 Adverse working conditions

Workpiece material	P Steel	M Stainless steel	K Cast iron	N Ferrite materials	S Heat-resistant steel
P Steel	😊	😊	😊	😊	😊
M Stainless steel	😊	😊	😊	😊	😊
K Cast iron	😊	😊	😊	😊	😊
N Ferrite materials	😊	😊	😊	😊	😊
S Heat-resistant steel	😊	😊	😊	😊	😊

Insert shape	Type	Dimensions (inch)					Coated grade									Uncoated grade			
		α	r	ϕd	S	$\phi I.C$	YBC302	YBM251	YBM253	YBM351	YBG102	YBG202	YBG212	YBG205	YBG302	YBS203	YBS303	YD101	YD201
	WPGT050315ZSR	11°	0.059	0.157	0.138	0.313	●			●									
	WPGT060415ZSR	11°	0.059	0.173	0.165	0.375	●			●									
	WPGT080615ZSR	11°	0.059	0.217	0.250	0.506	●			●									
	WPGT090725ZSR	11°	0.098	0.217	0.276	0.591	●			●									
	WPGT050315ZSR-PM	11°	0.059	0.157	0.138	0.313	●			●			●						
	WPGT060415ZSR-PM	11°	0.059	0.173	0.165	0.375	●			●			●						
	WPGT080615ZSR-PM	11°	0.059	0.217	0.250	0.506	●			●			●						
	WPGT090725ZSR-PM	11°	0.098	0.217	0.276	0.591	●			●			●						

● Always stock available ○ Produce according to order

Chipbreaker introduction:

-PM chipbreaker has sharp cutting edge. It is more suitable for machining with power shortage and for relatively adhesive materials, such as stainless steel and Ti alloy. etc.

General chipbreaker has blunt cutting edge and is relatively suitable for machining of hard materials such as hardened steel and cast iron. etc.



Approximate R in machining program

Applicable insert	Approximate R(in)	Cutting margin K(in)
WPGT050315ZSR/-PM	0.079	0.020
WPGT060415ZSR/-PM	0.098	0.028
WPGT080615ZSR/-PM	0.098	0.028
WPGT090725ZSR/-PM	0.177	0.047
SDMT06T208-DM/-PM/NM	0.063	0.020
SDMT09T312-DM/-PM/NM	0.098	0.034
SDMT120412-DM/-PM/NM	0.157	0.037
SDMT150520-DM/-PM	0.157	0.054

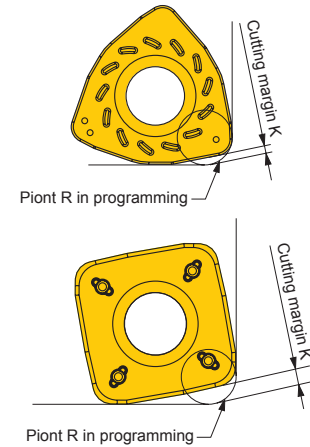

Ramp milling, helical interpolation milling

Insert	Max. cutting depth a_p (in)	Max. cutting depth α°	Min. diameter $\text{Ø}D_1$ (in)	Max. diameter (in)	Max. diameter (in)
WP**05**	0.75"	0.059	12.0	0.945	1.457
WP**06*	1.00"	0.059	8.8	1.220	1.850
	1.25"	0.059	5.0	1.772	2.402
	1.50"	0.059	3.2	2.402	3.031
	2.00"	0.059	2.8	3.189	3.819
WP**08*	1.50"	0.059	9.0	2.047	3.031
	2.00"	0.059	5.4	2.795	3.819
	2.50"	0.059	4.3	3.819	4.843
	3.00"	0.059	2.9	5.157	6.181
	4.00"	0.059	2.1	6.732	7.756
WP**09*	2.00"	0.118	7.2	2.756	3.780
	2.50"	0.118	4.5	3.780	4.803
	3.00"	0.118	2.8	5.118	6.142
	4.00"	0.118	2.2	6.693	7.717

Ramp milling

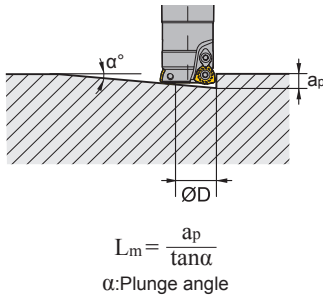

Helical interpolation milling

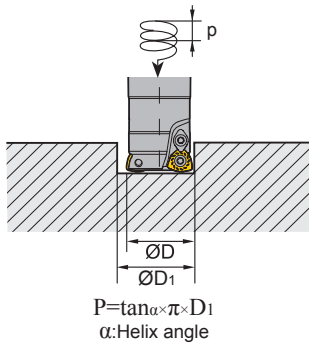

Reduce the feed rate when plunging and circular milling.
 For drilling operations (axial) set the feed rate under 0.008inch.
 "Attention"—drilling can form long chips.

Ramp milling, helical interpolation milling

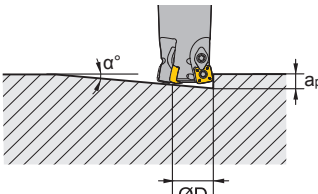
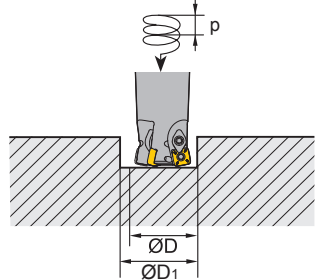
Insert	Diameter ØD(in)	Max.cutting depth ap(in)	Max.cutting depth α°	Min.diameter ØD1(in)	Max.diameter (in)	
<p>● Ramp milling</p>  $L_m = \frac{a_p}{\tan \alpha}$ <p>α: Plunge angle</p>	SD**06**	0.75"	0.032	3.600	1.181	1.496
		1.00"	0.032	2.800	1.575	1.890
		1.25"	0.032	1.600	2.047	2.362
		1.50"	0.032	1.100	2.756	3.071
		2.00"	0.032	0.800	3.543	3.858
		2.50"	0.032	0.700	4.488	4.803
<p>● Helical interpolation milling</p>  $P = \tan \alpha \times \pi \times D_1$ <p>α: Helix angle</p>	SD**09**	1.00"	0.055	6.500	1.339	1.890
		1.25"	0.055	4.500	1.890	2.441
		2.00"	0.055	1.800	3.307	3.858
		2.50"	0.055	1.300	4.331	4.882
<p>SD**12**</p>		1.25"	0.071	10.400	1.732	2.362
		1.50"	0.071	5.700	2.362	2.992
		1.75"	0.071	3.500	3.149	3.780
		2.50"	0.071	2.500	4.173	4.803
		3.00"	0.071	1.600	5.512	6.142
		4.00"	0.071	1.200	7.087	7.717
<p>SD**15**</p>		1.50"	0.087	7.300	2.126	2.992
		3.00"	0.087	1.400	5.276	6.142
		4.00"	0.087	1.000	6.850	7.717
		5.00"	0.087	0.900	9.213	9.685
		6.00"	0.087	0.600	11.970	12.441

Reduce the feed rate when plunging and circular milling.
 For drilling operations (axial) set the feed rate under 0.008inch.
 "Attention"—drilling can form long chips.



Recommended cutting parameters

Workpiece material	Hardness HB	Insert grade	Cutting speed (SFPM)	Ø0.75/Ø1.00		Ø1.25	
				Axial cutting depth	Feed rate per tooth	Axial cutting depth	Feed rate per tooth
P Soft steel Carbon Steel	≤HB180 HB180-280	YBM253	500 (300-650)	0.024~0.04	0.032~0.048	0.032~0.048	0.04~0.056
		YBM351					
		YBC302 YBG205					
Alloy steel Alloy tool steel	HB280-350 ≤HB350	YBM253	400 (260-600)	0.016~0.032	0.032~0.048	0.024~0.04	0.04~0.056
		YBM351 YBC302 YBG205					
pre-hardened steel	≤HRC35	YBM253 YBM351 YBC302 YBG205	400 (260-500)	0.016~0.032	0.024~0.04	0.024~0.04	0.032~0.048
M Stainless steel	≤HB270	YBM253 YBM351	400 (260-500)	0.024~0.04	0.024~0.04	0.032~0.048	0.032~0.048
		YBG202 YBG205	400 (260-600)				
K Common cast Iron	Tensile strength ≤350MPa	YBG202	500 (350-700)	0.024~0.04	0.04~0.056	0.032~0.048	0.048~0.064
		YBG302	500 (300-650)				
Nodular cast iron	Tensile strength ≤800MPa	YBG202 YBG302	400 (300-600) 400 (260-500)	0.016~0.032	0.032~0.048	0.024~0.04	0.04~0.056
S High-temperature alloy	≤400	YBG212	150 (60-200)	0.016~0.031	0.004~0.010	0.02~0.035	0.005~0.012
		YBS202	250 (200-400)	0.024~0.04	0.024~0.04	0.031~0.047	0.031~0.047
		YBS303	200 (250-350)	0.016~0.031	0.016~0.031	0.016~0.04	0.016~0.04

Recommended cutting parameters

Workpiece material	Hardness HB	Insert grade	Cutting speed (SFPM)	Ø1.50		Ø2.00/2.50		Ø3.00/4.00/5.00/6.00	
				Axial cutting depth	Feed rate per tooth	Axial cutting depth	Feed rate per tooth	Axial cutting depth	Feed rate per tooth
P Soft steel Carbon steel	≤HB180 HB180-280	YBM253	500 (300-650)	0.032~0.048	0.04~0.056	0.043~0.06	0.043~0.06	0.04~0.06	0.04~0.06
		YBM351							
		YBC302 YBG205							
Alloy steel Alloy tool steel	HB280-350 ≤HB350	YBM253	400 (260-600)	0.024~0.04	0.04~0.056	0.035~0.051	0.43~0.06	0.032~0.051	0.04~0.06
		YBM351 YBC302 YBG205							
Pre-hardened steel	≤HRC35	YBM253 YBM351 YBC302 YBG205	400 (260-500)	0.024~0.04	0.032~0.048	0.035~0.051	0.035~0.051	0.032~0.051	0.032~0.051
M Stainless steel	≤HB270	YBM253 YBM351	400 (260-500)	0.032~0.048	0.032~0.048	0.043~0.06	0.035~0.051	0.04~0.06	0.032~0.051
		YBG202 YBG205	400 (260-600)						
K Common cast iron	Tensile strength ≤350MPa	YBG202	500 (350-700)	0.032~0.048	0.048~0.064	0.043~0.06	0.051~0.067	0.04~0.06	0.048~0.067
		YBG302	500 (300-650)						
Nodular cast iron	Tensile strength ≤800MPa	YBG202 YBG302	400 (300-600) 400 (260-500)	0.024~0.040	0.04~0.056	0.035~0.051	0.043~0.06	0.032~0.051	0.04~0.06
S High-temperature alloy	≤400	YBG212	150 (60-200)	0.02~0.035	0.005~0.016	0.03~0.047	0.006~0.016	0.03~0.05	0.005~0.02
		YBS203	250 (200-400)	0.031~0.047	0.024~0.04	0.043~0.059	0.024~0.047	0.04~0.059	0.016~0.047
		YBS303	200 (250-350)	0.016~0.04	0.016~0.04	0.024~0.047	0.024~0.04	0.016~0.04	0.016~0.031

Chamfer milling tools

Kr:45°



CMA01

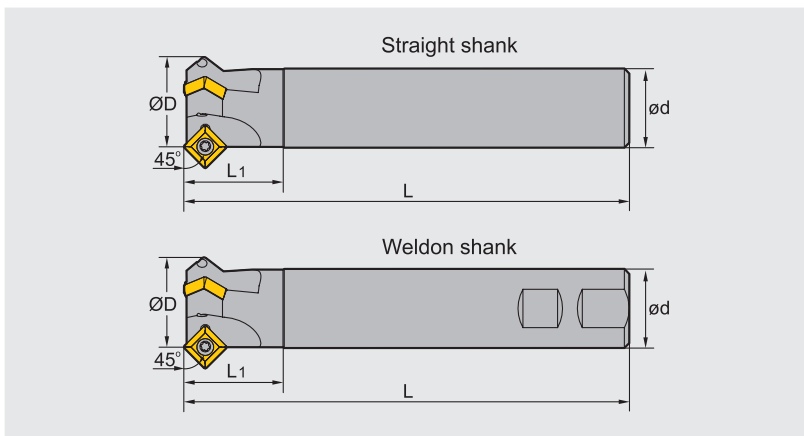

P M K



Specification of tools

Type		Dimensions(inch)				
		ØD	ød	L	L ₁	Z (Number of teeth)
CMA01 Cylindrical	-0.50"-G0.75"-SP12-01	0.50	0.75	4.00	1.50	1
	-1.00"-G1.00"-SP12-02	1.00	1.00	5.00	1.50	2
	-1.25"-G1.25"-SP12-03	1.25	1.25	7.00	1.50	3
Weldon	-0.50"-XP0.75"-SP12-01	0.50	0.75	4.00	1.50	1
	-1.00"-XP1.00"-SP12-02	1.00	1.00	5.00	1.50	2
	-1.25"-XP1.25"-SP12-03	1.25	1.25	7.00	1.50	3

Spare parts

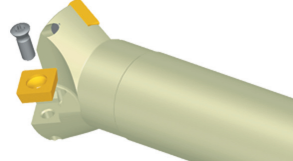
Diameter ØD	Screw	Wrench	Sketch of installation
0.50"~1.25"	 I43M5×11	 WT20IS	

Chamfer milling tools

Kr:60°



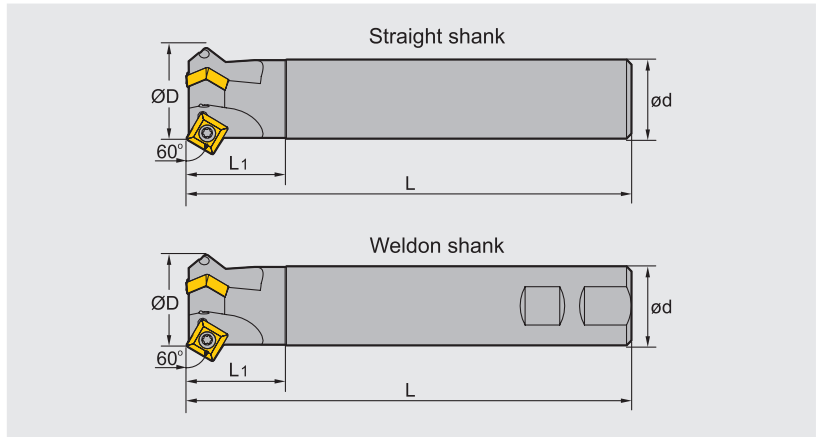

CMD01



Specification of tools

Type		Dimensions(inch)				
		ØD	ød	L	L1	Z (Number of teeth)
CMD01 Straight shank	-0.50" -G0.75" -SP12-01	0.50	0.75	4.00	1.50	1
	-1.00" -G1.00" -SP12-02	1.00	1.00	5.00	1.50	2
	-1.25" -G1.25" -SP12-03	1.25	1.25	7.00	1.50	3
Weldon shank	-0.50" -XP0.75" -SP12-01	0.50	0.75	4.00	1.50	1
	-1.00" -XP1.00" -SP12-02	1.00	1.00	3.00	1.50	2
	-1.25" -XP1.25" -SP12-03	1.25	1.25	7.00	1.50	3

Spare parts

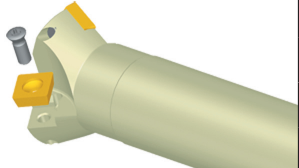
Diameter ØD	Screw	Wrench	Sketch of installation
0.50"~1.25"	 I43M5×11	 WT20IS	

Common problems and solutions for milling

Main points of solution and inspection		Selection of tool material		Cutting condition					Tool shape						Machine clamping system					
		Material with higher hardness	Material with perfect roughness	Cutting speed	Feed rate	Cutting depth	Change the diameter and width of milling tools	Cutting liquid	Rake angle	Approach angle	Strength of cutting edge	Number of teeth	Increase the width of chip pocket	Examine the geometry shape of Minor cutting edge.	check the end face run-out	Improve the rigidity of tool	Clamping system of workpiece	Overhang of tool	Power, gap	
Failure																				
Fracture of tool nose	Severe abrasion on clearance face	Improper cutting condition			↓				✓											
		Unsuitable geometry shape of cutting edge	✓							↑		↓								
	Severe abrasion on rake face	Improper cutting condition			↓	↓	↓		✓											
		Unsuitable geometry shape of cutting edge	✓							↑	↓	↓								
	Fracture of cutting edge	Improper cutting condition				↓	↓													
		Unsuitable geometry shape of cutting edge		✓							↓	↑		✓	✓	✓	✓	✓	✓	✓
	Thermal cracking	Improper cutting condition			↓	↓	↓		✓											
		Unsuitable geometry shape of cutting edge								↑		↓								
Build-up edge	Improper cutting condition			↑	↑			✓												
	Unsuitable geometry shape of cutting edge								↑		↓									
Machining precision	Bad surface roughness	Abrasion of tool Great vibration of milling tool	✓		↑	↓	↓		✓		↓		Wiper	✓						
		Unsuitable geometry shape of cutting edge			↓	↓	↓	✓												
	Burrs occurring	Improper geometry shape of cutting edge								↑	↑	↓		✓						
		Unsuitable geometry shape of cutting edge				↓	↓													
	Side collapse	Unsuitable geometry shape of cutting edge								↑	↓	↓	↑	✓		✓				
Improper geometry Improper technique					↓	↓			↑	↑		↓	✓	✓	✓	✓	✓	✓	✓	
Other	Great vibration	Cutting condition Improper technology			↓	↓	↓	✓		↑	↑	↓				✓	✓	✓	✓	
		Improper cutting condition			↑	↑	↓	✓	✓				↓							
	Chips twisting and jamming	Unsuitable geometry shape of cutting edge								↑			↓	✓						

*New product for
milling*

HMX

*High hardness
machining series*

