

Boring Tools

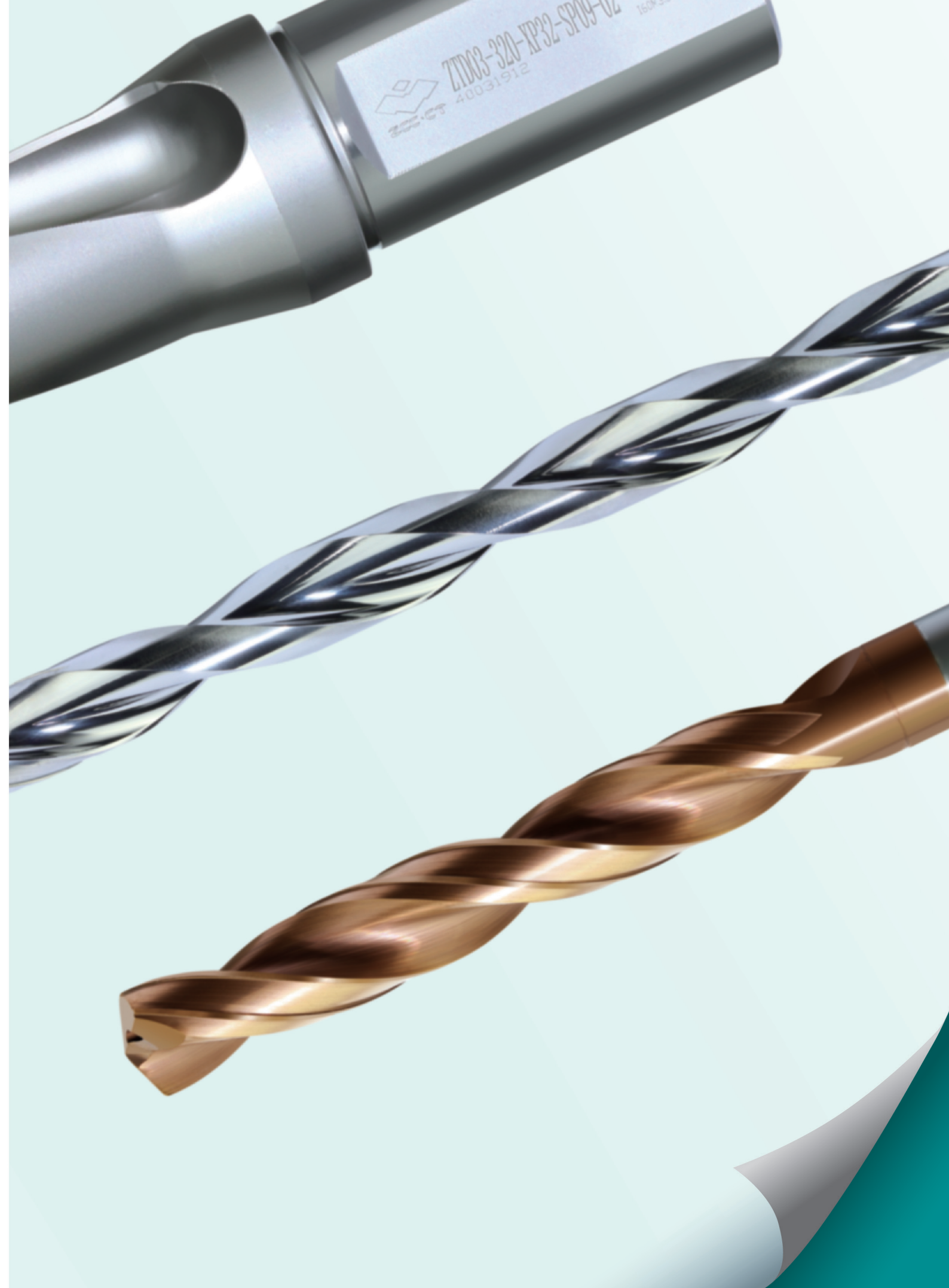



ZT003-320-XP32-SP09-02
40031912



GD series

*Universal-purpose
twist drill*



Boring tools

BORING TOOLS

Drills	P356-433
Drilling tools overview	P360
Solid carbide drills	P356-409
Solid carbide drills code key	P361
Grade introduction of solid carbide drills	P362
GD series drills	P363-394
SL series drills	P395-404
Technical information for solid carbide drills	P405-409
Indexable shallow drills	P410-433
Shallow drills code key	P411
Shallow drills overview	P414-431
Shallow drilling inserts overview	P432
Recommended cutting parameters for shallow drills	P433

GD series universal machining

GD03 ▶ P365-394



GD03C ▶ P365-394



GD05 ▶ P365-394



GD05C ▶ P365-394



GD08C ▶ P365-394



SL series deep hole machining

1588SL ▶ P399-404



Indexable shallow drills

ZSD02/03/04/05 ▶ P414-421



ZTD03/04/05 ▶ P426-431



Solid carbide drills code key

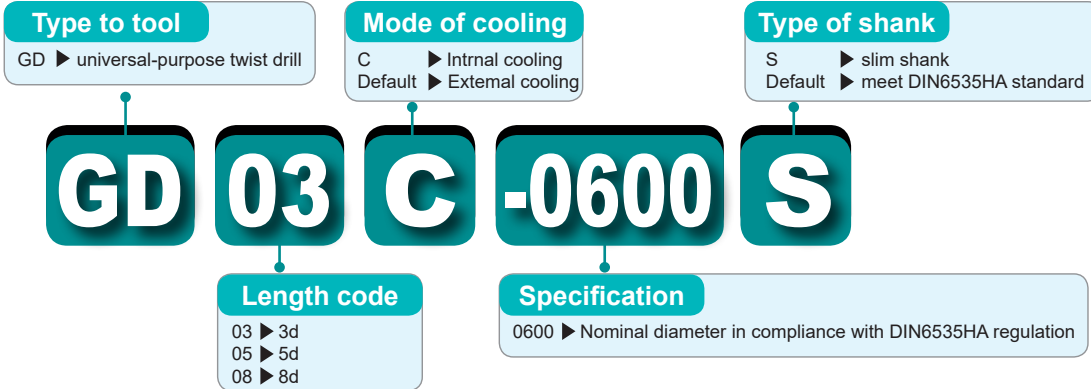

Code	Description
1	As per DIN338
2	As per DIN1897
3	As per QJ/ZZQ(TO)01.001.002
4	As per DIN6537K
5	As per DIN6537K
6	As per DIN6537K
7	As per the rule ZZC-C in QJ/ZZQ(TO)01.001.002
8	As per the rule ZZC-D in QJ/ZZQ(TO)01.001.002
9	As per the rule ZZC-E in QJ/ZZQ(TO)01.001.002

Length code

Code	Description
SL	Deep twist drills
ST	Twist drill for soft steel, stainless steel
PC	Straight flute drill for aluminum, cast iron

Geometry

Code	Description
1	Drills

Type to tool

Code	Description
C	Internal coolant
Default	External coolant

Mode of cooling



Code	Description
1	Straight shank
2	Square head straight shank as per DIN10
3	Double flattened straight shank as per DIN1809
5	Straight shank as per DIN6535HA
7	Whistle notch shank as per DIN6535HE
9	Tapered shank

Type of shank

Code	Description
0	Twist drill
3	Multiple functions twist drill
4	Centering drill
5	Step drill
7	Straight flute drill
8	Deep drill

Type of drill

Code	Description
0850	Nominal diameter of drill

Specification

Identification of drilling depth			
Cutting depth shown when the tool is non-pilot drill		Point angle identification shown when tool is pilot drill	
Code	Description	Code	Description
03	(2~3) d	90	pilot drill with 90° point angle
05	(4~5) d		
08	(7~8) d		
12	(12) d	120	pilot drill with 120° point angle
15	(15) d		
20	(20) d		
30	(30) d		



Grade introduction of solid carbide drills

Coated grade

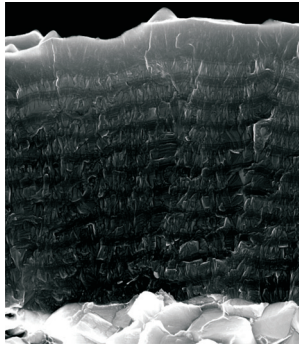

AlCrN substrate composite coating

KDG8013

New AlCrN substrate composite coating, with excellent abrasion resistance and bonding resistance, improves the stability of the insert edge.

Unique coating after-treatment technology effectively reduces the cutting resistance for smoother chip evacuation and higher security.

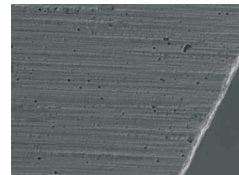

KDG3013

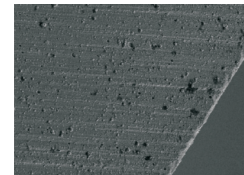

Conventional coating

KDG303

Ultra-fine carbide substrate with high strength, toughness and wear resistance, in combination with nano-structured nc-TiAlN coating aiming at optimizing drilling operations, makes sure the tools have very high toughness and hardness. Unique coating technology gives the tools smooth surface and excellent wear resistance, and outstanding thermal stability and chemical stability provide effective protection for the cutting edge.

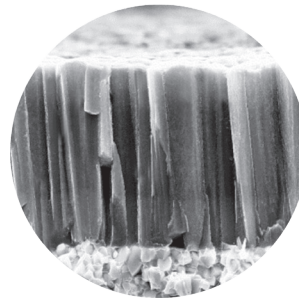

Common TiAlN coating

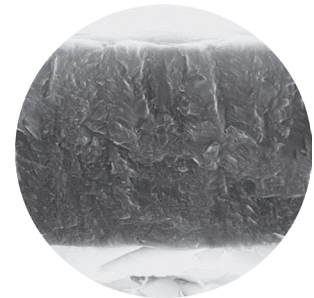

nc-TiAlN coating

Uncoated grade

YK20F

Ultra-fine grain carbide substrate with high hardness, outstanding wear resistance, and long tool life.

YK30F

Ultra-fine carbide substrate with high strength, toughness and wear resistance gives the cutting edge perfect strength.

GD series Universal-purpose

Application range

Versatile, for high efficiency machining in a variety of material e.g. P(steel), M(stainless steel), K (Cast iron).



Linear cutting edge with high strength.
Optimized drill point structure for better cutting performance.

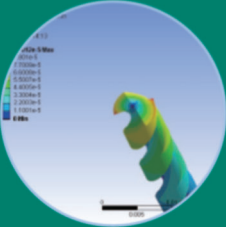

Simulation in combination with testing for superior overall performance.



Professional after treatment for coating ensures low-resistance high-efficiency machining.



Double edge-line design for improved machining stability.

Long and stable tool life

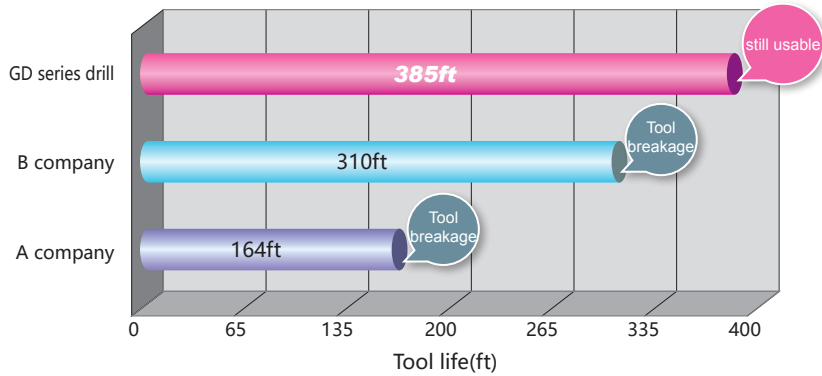

tool: GD05C-0560
 workpiece material: P20 mod.
 $V_c=320\text{SFPM}$; $f_r=0.0059\text{in/r}$; $H=1.063\text{in}$
 cooling system: water soluble cooling

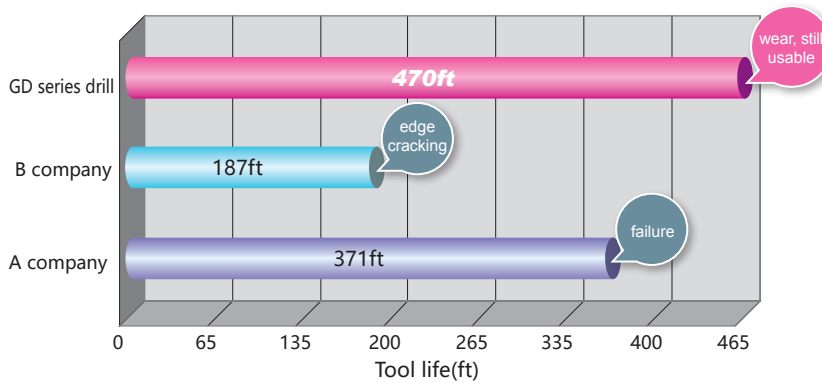

tool: GD05C-1000
 workpiece material: 1045
 $V_c=490\text{SFPM}$; $f_r=0.0098\text{in/r}$; $H=1.575\text{in}$
 cooling system: water soluble cooling

outstanding machining precision

quality of hole wall:

tool: GD03C-0820
 workpiece material: P20 mod.
 $V_c=380\text{SFPM}$; $f_r=0.0091\text{in/r}$; $H=1.181\text{in}$
 cooling system: water soluble cooling

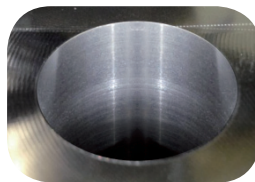

GD series drill



A company

excellent chip breaking performance

chip breaking performance:

tool: GD05C-0600
 workpiece material: 321
 $V_c=240\text{SFPM}$; $f_r=0.0079\text{in/r}$; $H=1.181\text{in}$
 cooling system: water soluble cooling



GD series drill



A company

GD series universal machining

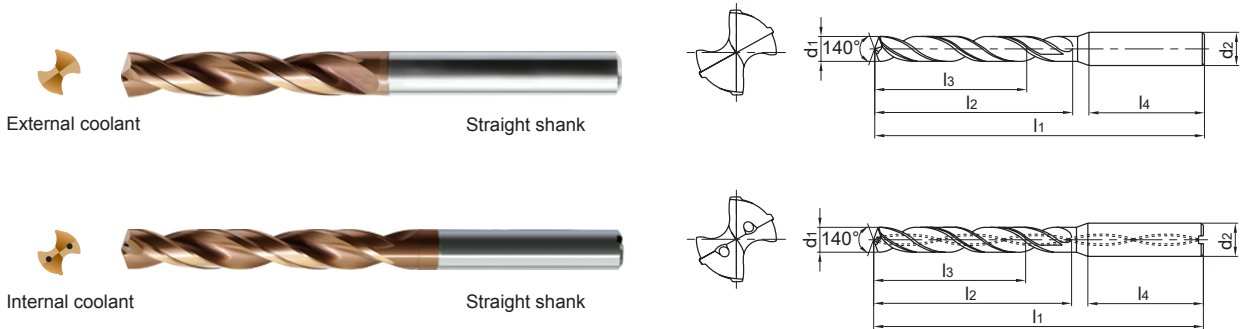

● Suitable for high efficiency drilling in a variety of materials e.g steel, stainless steel, cast iron.

Drill diameter d ₁ (m7)			Drilling depth (l/d)	Cooling mode	Shank type	Type	Basic dimension(mm)					Suitable for thread		Grade
mm	inch	Fraction					Shank diameter d ₂ (h6)	Overall length l ₁	Flute length l ₂	Recommended drilling depth l ₃	Shank length l ₄	cutting taps / tread milling cutters	forming taps	
2.0	0.0787	--	3	External coolant	Straight shank	GD03-0200	4	58	13	9	28		NO.2-64UNF	●
	0.0787	--	5			GD05-0200	4	58	18	14	28			●
2.1	0.0827	--	3			GD03-0210	4	58	13	9	28	NO.3-48UNC	●	
	0.0827	--	5			GD05-0210	4	58	18	14	28		●	
2.15	0.0846	--	3			GD03-0215	4	58	13	9	28	NO.3-56UNF	●	
	0.0846	--	5			GD05-0215	4	58	18	14	28		●	
2.2	0.0866	--	3			GD03-0220	4	58	13	9	28		●	
	0.0866	--	5			GD05-0220	4	58	18	14	28		●	
2.3	0.0906	--	3			GD03-0230	4	58	13	9	28	M2.5×0.45	●	
	0.0906	--	5			GD05-0230	4	58	18	14	28		NO.3-56UNF	●
2.35	0.0925	--	3			GD03-0235	4	58	17	12	28	NO.4-40UNC	●	
	0.0925	--	5			GD05-0235	4	58	22	17	28		●	
2.4	0.0945	--	3			GD03-0240	4	58	17	12	28	NO.4-48UNF	●	
	0.0945	--	5			GD05-0240	4	58	22	17	28		●	
2.5	0.0984	--	3			GD03-0250	4	58	17	12	28	M3×0.5	●	
	0.0984	--	5			GD05-0250	4	58	22	17	28		●	
2.55	0.1004	--	3			GD03-0255	4	58	17	12	28	NO.4-40UNC	●	
	0.1004	--	5			GD05-0255	4	58	22	17	28		●	
2.6	0.1024	--	3			GD03-0260	4	58	17	12	28	NO.4-48UNF	●	
	0.1024	--	5			GD05-0260	4	58	22	17	28		●	
2.65	0.1043	--	3	GD03-0265	4	58	17	12	28	NO.5-40UNC	●			
	0.1043	--	5	GD05-0265	4	58	22	17	28		●			

Note: For drilling depth (l/d) of 8 ,namely GD08C series, tolerance of shank diameter is h₈.

● Stock available ○ Make-to-order

Applicable material table

○ Very suitable ○ Suitable

Grade	Workpiece material										
	Mild steel HB ≤ 180	Carbon steel, Alloy steel	Pre-hardened steel, Hardened steel			Stainless steel	Cast iron	Nodular cast iron	Aluminum alloy	Copper alloy	Heat resistant alloy
			~40HRC	~50HRC	~60HRC						
KDG3013	○	○	○			○	○	○			○

GD series universal machining

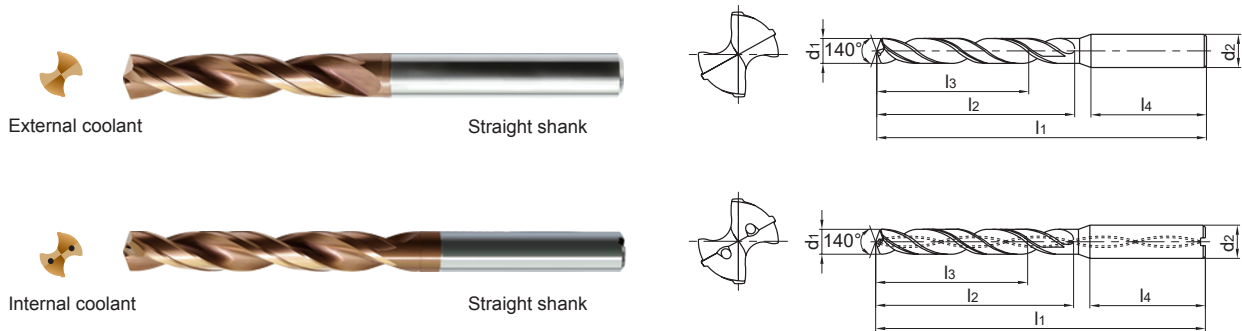

● Suitable for high efficiency drilling in a variety of materials e.g steel, stainless steel, cast iron.

Drill diameter d ₁ (m7)			Drilling depth (l/d)	Cooling mode	Shank type	Type	Basic dimension(mm)					Suitable for thread		Grade
mm	inch	Fraction					Shank diameter	Overall length	Flute length	Recommended drilling depth	Shank length	cutting taps / tread milling cutters	forming taps	
							d2(h6)	l1	l2	l3	l4			KDG3013
2.7	0.1063	--	3	External coolant	Straight shank	GD03-0270	4	58	17	12	28	NO.5-44UNF		●
	0.1063	--	5			GD05-0270	4	58	22	17	28			●
2.8	0.1102	--	3			GD03-0280	4	58	17	12	28	M3×0.5		●
	0.1102	--	5			GD05-0280	4	58	22	17	28			●
2.85	0.1122	--	3			GD03-0285	4	58	17	12	28	NO.6-32UNC		●
	0.1122	--	5			GD05-0285	4	58	22	17	28			●
2.9	0.1142	--	3			GD03-0290	4	58	17	12	28	NO.5-40UNC		●
	0.1142	--	5			GD05-0290	4	58	22	17	28			NO.5-44UNF
2.95	0.1161	--	3			GD03-0295	4	58	17	12	28	NO.6-40UNF		●
	0.1161	--	5			GD05-0295	4	58	22	17	28			●
3.0	0.1181	--	3	GD03-0300	6	62	20	14	36			●		
	0.1181	--	5	GD05-0300	6	66	28	23	36			●		
	0.1181	--	3	GD03C-0300	6	62	20	14	36			●		
	0.1181	--	5	GD05C-0300	6	66	28	23	36			●		
	0.1181	--	8	GD08C-0300	6	72	34	29	36			○		
3.1	0.1220	--	3	GD03-0310S	4	62	20	14	36			●		
	0.1220	--	5	GD05-0310S	4	66	28	23	36			●		
	0.1220	--	3	GD03C-0310S	4	62	20	14	36			●		
	0.1220	--	5	GD05C-0310S	4	66	28	23	36			●		
	0.1220	--	3	GD03-0310	6	62	20	14	36			○		
	0.1220	--	5	GD05-0310	6	66	28	23	36			○		
	0.1220	--	3	GD03C-0310	6	62	20	14	36			○		
	0.1220	--	5	GD05C-0310	6	66	28	23	36			○		
	0.1220	--	8	GD08C-0310	6	72	34	29	36			○		
3.175	0.1250	1/8	3	GD03-03175S	4	62	20	14	36			●		
	0.1250	1/8	5	GD05-03175S	4	66	28	23	36			●		
	0.1250	1/8	3	GD03C-03175S	4	62	20	14	36			●		
	0.1250	1/8	5	GD05C-03175S	4	66	28	23	36			●		

● Stock available ○ Make-to-order

Drill diameter d ₁ (mm)			Drilling depth (l/d)	Cooling mode	Shank type	Type	Basic dimension(mm)					Suitable for thread		Grade
mm	inch	Fraction					Shank diameter d ₂ (h ₆)	Overall length l ₁	Flute length l ₂	Recommended drilling depth l ₃	Shank length l ₄	cutting taps / tread milling cutters	forming taps	
3.175	0.1250	1/8	3	External coolant	Straight shank	GD03-03175	6	62	20	14	36	NO.6-40UNF	○	
	0.1250	1/8	5			GD05-03175	6	66	28	23	36		○	
	0.1250	1/8	3	Internal coolant		GD03C-03175	6	62	20	14	36		○	
	0.1250	1/8	5			GD05C-03175	6	66	28	23	36		○	
3.2	0.1260	--	3	External coolant		GD03-0320S	4	62	20	14	36		●	
	0.1260	--	5			GD05-0320S	4	66	28	23	36		●	
	0.1260	--	3	Internal coolant		GD03C-0320S	4	62	20	14	36		●	
	0.1260	--	5			GD05C-0320S	4	66	28	23	36		●	
	0.1260	--	3	External coolant	GD03-0320	6	62	20	14	36	○			
	0.1260	--	5		GD05-0320	6	66	28	23	36	○			
	0.1260	--	3	Internal coolant	GD03C-0320	6	62	20	14	36	○			
	0.1260	--	5		GD05C-0320	6	66	28	23	36	○			
3.25	0.1260	--	8	Internal coolant	GD08C-0320	6	72	34	29	36	○			
	0.1280	--	3		External coolant	GD03-0325S	4	62	20	14	36	●		
	0.1280	--	5			GD05-0325S	4	66	28	23	36	●		
	0.1280	--	3		Internal coolant	GD03C-0325S	4	62	20	14	36	●		
	0.1280	--	5			GD05C-0325S	4	66	28	23	36	●		
	0.1280	--	3		External coolant	GD03-0325	6	62	20	14	36	○		
	0.1280	--	5			GD05-0325	6	66	28	23	36	○		
	0.1280	--	3		Internal coolant	GD03C-0325	6	62	20	14	36	○		
0.1280	--	5	GD05C-0325	6		66	28	23	36	○				
3.3	0.1299	--	3	External coolant	GD03-0330S	4	62	20	14	36	●			
	0.1299	--	5		GD05-0330S	4	66	28	23	36	●			
	0.1299	--	3	Internal coolant	GD03C-0330S	4	62	20	14	36	●			
	0.1299	--	5		GD05C-0330S	4	66	28	23	36	●			
	0.1299	--	3	External coolant	GD03-0330	6	62	20	14	36	○			
	0.1299	--	5		GD05-0330	6	66	28	23	36	○			
	0.1299	--	3	Internal coolant	GD03C-0330	6	62	20	14	36	○			
	0.1299	--	5		GD05C-0330	6	66	28	23	36	○			
0.1299	--	8	Internal coolant	GD08C-0330	6	72	34	29	36	○				

Note: For drilling depth (l/d) of 8, namely GD08C series, tolerance of shank diameter is h₈.

● Stock available ○ Make-to-order



▶ Applicable material table

◎ Very suitable ○ Suitable

Grade	Workpiece material										
	Mild steel HB ≤ 180	Carbon steel, Alloy steel	Pre-hardened steel, Hardened steel			Stainless steel	Cast iron	Nodular cast iron	Aluminum alloy	Copper alloy	Heat resistant alloy
			~40HRC	~50HRC	~60HRC						
KDG3013	○	◎	◎			○	◎	◎			○

GD series universal machining

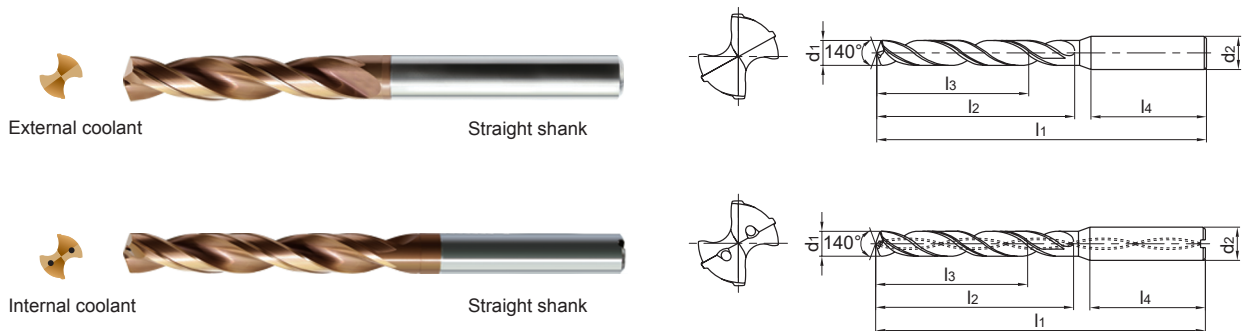

● Suitable for high efficiency drilling in a variety of materials e.g steel, stainless steel, cast iron.

Drill diameter d ₁ (m ₇)			Drilling depth (l/d)	Cooling mode	Shank type	Type	Basic dimension(mm)					Suitable for thread		Grade		
mm	inch	Fraction					Shank diameter	Overall length	Flute length	Recommended drilling depth	Shank length	cutting taps / tread milling cutters	forming taps			
									d ₂ (h ₆)	l ₁	l ₂	l ₃	l ₄			
3.4	0.1339	--	3	External coolant	Straight shank	GD03-0340S	4	62	20	14	36	M4×0.5 NO.8-32UNC NO.8-36UNF		●		
	0.1339	--	5			GD05-0340S	4	66	28	23	36			●		
	0.1339	--	3	Internal coolant		GD03C-0340S	4	62	20	14	36			●		
	0.1339	--	5			GD05C-0340S	4	66	28	23	36			●		
	0.1339	--	3	External coolant		GD03-0340	6	62	20	14	36			○		
	0.1339	--	5			GD05-0340	6	66	28	23	36			○		
	0.1339	--	3	Internal coolant		GD03C-0340	6	62	20	14	36			○		
	0.1339	--	5			GD05C-0340	6	66	28	23	36			○		
0.1339	--	8	GD08C-0340	6		72	34	29	36	○						
3.5	0.1378	--	3	External coolant		GD03-0350S	4	62	20	14	36			M4×0.5 NO.8-32UNC NO.8-36UNF		●
	0.1378	--	5			GD05-0350S	4	66	28	23	36					●
	0.1378	--	3	Internal coolant		GD03C-0350S	4	62	20	14	36					●
	0.1378	--	5			GD05C-0350S	4	66	28	23	36					●
	0.1378	--	3	External coolant		GD03-0350	6	62	20	14	36					○
	0.1378	--	5			GD05-0350	6	66	28	23	36					○
	0.1378	--	3	Internal coolant		GD03C-0350	6	62	20	14	36					○
	0.1378	--	5		GD05C-0350	6	66	28	23	36	○					
0.1378	--	8	GD08C-0350	6	72	34	29	36	○							
3.6	0.1417	--	3	External coolant	GD03-0360S	4	62	20	14	36	M4×0.5 NO.8-32UNC NO.8-36UNF		●			
	0.1417	--	5		GD05-0360S	4	66	28	23	36			●			
	0.1417	--	3	Internal coolant	GD03C-0360S	4	62	20	14	36			●			
	0.1417	--	5		GD05C-0360S	4	66	28	23	36			●			
	0.1417	--	3	External coolant	GD03-0360	6	62	20	14	36			○			
	0.1417	--	5		GD05-0360	6	66	28	23	36			○			
	0.1417	--	3	Internal coolant	GD03C-0360	6	62	20	14	36			○			
	0.1417	--	5		GD05C-0360	6	66	28	23	36			○			
0.1417	--	8	GD08C-0360	6	72	34	29	36	○							
3.7	0.1457	--	3	External coolant	GD03-0370S	4	62	20	14	36	M4×0.7		●			
	0.1457	--	5		GD05-0370S	4	66	28	23	36			●			

● Stock available ○ Make-to-order

Drill diameter d ₁ (m ₇)			Drilling depth (l/d)	Cooling mode	Shank type	Type	Basic dimension(mm)					Suitable for thread		Grade
mm	inch	Fraction					Shank diameter	Overall length	Flute length	Recommended drilling depth	Shank length	cutting taps / tread milling cutters	forming taps	
3.7	0.1457	--	3	Internal coolant	Straight shank	GD03C-0370S	4	62	20	14	36	M4×0.7	●	
	0.1457	--	5			GD05C-0370S	4	66	28	23	36		●	
	0.1457	--	3	External coolant		GD03-0370	6	62	20	14	36		○	
	0.1457	--	5			GD05-0370	6	66	28	23	36		○	
	0.1457	--	3	Internal coolant		GD03C-0370	6	62	20	14	36		○	
	0.1457	--	5			GD05C-0370	6	66	28	23	36		○	
	0.1457	--	8	GD08C-0370		6	72	34	29	36	○			
	3.8	0.1496	--	3		External coolant	GD03-0380S	4	66	24	17		36	M4×0.5 NO.8-32UNC
0.1496		--	5	GD05-0380S	4		74	36	29	36	●			
0.1496		--	3	Internal coolant	GD03C-0380S	4	66	24	17	36	●			
0.1496		--	5		GD05C-0380S	4	74	36	29	36	●			
0.1496		--	3	External coolant	GD03-0380	6	66	24	17	36	○			
0.1496		--	5		GD05-0380	6	74	36	29	36	○			
0.1496		--	3	Internal coolant	GD03C-0380	6	66	24	17	36	○			
0.1496		--	5		GD05C-0380	6	74	36	29	36	○			
3.85	0.1516	--	3	External coolant	Straight shank	GD03-0385S	4	66	24	17	36	NO.8-36UNF	●	
	0.1516	--	5			GD05-0385S	4	74	36	29	36		●	
	0.1516	--	3	Internal coolant		GD03C-0385S	4	66	24	17	36		●	
	0.1516	--	5			GD05C-0385S	4	74	36	29	36		●	
	0.1516	--	3	External coolant		GD03-0385	6	66	24	17	36		○	
	0.1516	--	5			GD05-0385	6	74	36	29	36		○	
	0.1516	--	3	Internal coolant		GD03C-0385	6	66	24	17	36		○	
	0.1516	--	5			GD05C-0385	6	74	36	29	36		○	
3.9	0.1535	--	3	External coolant	Straight shank	GD03-0390S	4	66	24	17	36	NO.10-24UNC	●	
	0.1535	--	5			GD05-0390S	4	74	36	29	36		●	
	0.1535	--	3	Internal coolant		GD03C-0390S	4	66	24	17	36		●	
	0.1535	--	5			GD05C-0390S	4	74	36	29	36		●	
	0.1535	--	3	External coolant		GD03-0390	6	66	24	17	36		○	
	0.1535	--	5			GD05-0390	6	74	36	29	36		○	
	0.1535	--	3	Internal coolant		GD03C-0390	6	66	24	17	36		○	
	0.1535	--	5			GD05C-0390	6	74	36	29	36		○	
0.1535	--	8	GD08C-0390	6	81	43	36	36	○					

Note: For drilling depth (l/d) of 8 ,namely GD08C series, tolerance of shank diameter is h₈.

● Stock available ○ Make-to-order

Applicable material table

◎ Very suitable ○ Suitable

Grade	Workpiece material										
	Mild steel HB ≤ 180	Carbon steel, Alloy steel	Pre-hardened steel, Hardened steel			Stainless steel	Cast iron	Nodular cast iron	Aluminum alloy	Copper alloy	Heat resistant alloy
			~40HRC	~50HRC	~60HRC						
KDG3013	○	◎	◎			○	◎	◎			○

GD series universal machining

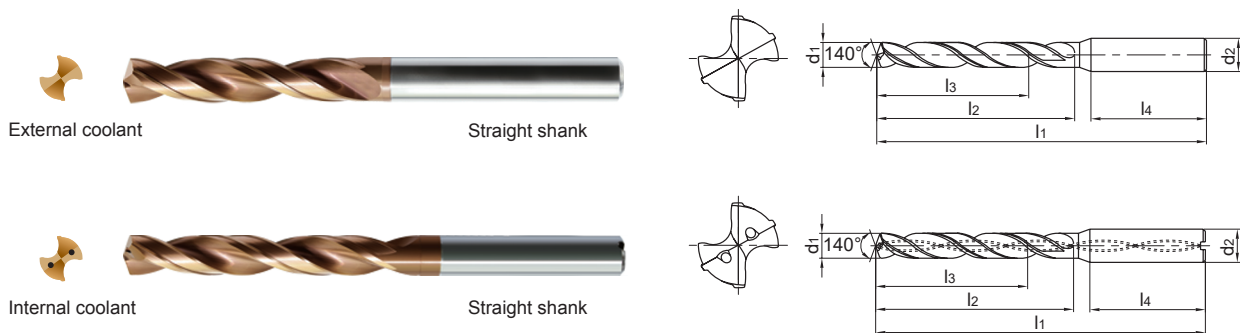

● Suitable for high efficiency drilling in a variety of materials e.g steel, stainless steel, cast iron.

Drill diameter d ₁ (m ₇)			Drilling depth (l/d)	Cooling mode	Shank type	Type	Basic dimension(mm)					Suitable for thread		Grade		
mm	inch	Fraction					Shank diameter	Overall length	Flute length	Recommended drilling depth	Shank length	cutting taps / tread milling cutters	forming taps			
							d ₂ (h ₆)	l ₁	l ₂	l ₃	l ₄			KDG3013		
3.97	0.1563	5/32	3	External coolant	Straight shank	GD03-03970S	4	66	24	17	36			●		
			5			GD05-03970S	4	74	36	29	36			●		
	0.1563	5/32	3	Internal coolant		GD03C-03970S	4	66	24	17	36			●		
			5			GD05C-03970S	4	74	36	29	36			●		
	0.1563	5/32	3	External coolant		GD03-03970	6	66	24	17	36					○
			5			GD05-03970	6	74	36	29	36					○
	0.1563	5/32	3	Internal coolant		GD03C-03970	6	66	24	17	36					○
			5			GD05C-03970	6	74	36	29	36					○
4.0	0.1575	--	3	External coolant	GD03-0400S	4	66	24	17	36			●			
			5		GD05-0400S	4	74	36	29	36			●			
	0.1575	--	3	Internal coolant	GD03C-0400S	4	66	24	17	36			●			
			5		GD05C-0400S	4	74	36	29	36			●			
	0.1575	--	3	External coolant	GD03-0400	6	66	24	17	36			○			
			5		GD05-0400	6	74	36	29	36			○			
	0.1575	--	3	Internal coolant	GD03C-0400	6	66	24	17	36			○			
			5		GD05C-0400	6	74	36	29	36			○			
0.1575	--	3	External coolant	GD03C-0400	6	66	24	17	36			○				
		5		GD05C-0400	6	74	36	29	36			○				
4.1	0.1614	--	3	External coolant	GD03-0410	6	66	24	17			36			●	
			5		GD05-0410	6	74	36	29			36			●	
	0.1614	--	3	Internal coolant	GD03C-0410	6	66	24	17			36			NO.10-32UNF	●
			5		GD05C-0410	6	74	36	29			36			●	
	0.1614	--	8		GD08C-0410	6	81	43	36			36			○	
4.2	0.1654	--	3	External coolant	GD03-0420	6	66	24	17			36			●	
			5		GD05-0420	6	74	36	29	36	●					
	0.1654	--	3	Internal coolant	GD03C-0420	6	66	24	17	36	M5×0.8	●				
			5		GD05C-0420	6	74	36	29	36	●					
	0.1654	--	8		GD08C-0420	6	81	43	36	36	○					
4.3	0.1693	--	3	External coolant	GD03-0430	6	66	24	17	36			●			
			5		GD05-0430	6	74	36	29	36			●			

● Stock available ○ Make-to-order

Drill diameter d ₁ (mm)			Drilling depth (l/d)	Cooling mode	Shank type	Type	Basic dimension(mm)					Suitable for thread		Grade
mm	inch	Fraction					Shank diameter d ₂ (h ₆)	Overall length l ₁	Flute length l ₂	Recommended drilling depth l ₃	Shank length l ₄	cutting taps / tread milling cutters	forming taps	
4.3	0.1693	--	3	Internal coolant	Straight shank	GD03C-0430	6	66	24	17	36	NO.10-24UNC	●	
	0.1693	--	5			GD05C-0430	6	74	36	29	36		●	
	0.1693	--	8			GD08C-0430	6	81	43	36	36		○	
4.35	0.1713	--	3	External coolant		GD03-0435	6	66	24	17	36		NO.10-24UNC	●
	0.1713	--	5			GD05-0435	6	74	36	29	36			●
	0.1713	--	3	Internal coolant		GD03C-0435	6	66	24	17	36			●
	0.1713	--	5			GD05C-0435	6	74	36	29	36			●
4.4	0.1732	--	3	External coolant		GD03-0440	6	66	24	17	36		NO.10-24UNC	●
	0.1732	--	5			GD05-0440	6	74	36	29	36			●
	0.1732	--	3	Internal coolant		GD03C-0440	6	66	24	17	36			●
	0.1732	--	5			GD05C-0440	6	74	36	29	36			●
4.45	0.1752	--	3	External coolant		GD03-0445	6	66	24	17	36		NO.10-32UNF	●
	0.1752	--	5		GD05-0445	6	74	36	29	36	●			
	0.1752	--	3	Internal coolant	GD03C-0445	6	66	24	17	36	●			
	0.1752	--	5		GD05C-0445	6	74	36	29	36	●			
4.5	0.1772	--	3	External coolant	GD03-0450	6	66	24	17	36	NO.12-24UNC M5×0.5	●		
	0.1772	--	5		GD05-0450	6	74	36	29	36		●		
	0.1772	--	3	Internal coolant	GD03C-0450	6	66	24	17	36		●		
	0.1772	--	5		GD05C-0450	6	74	36	29	36		●		
	0.1772	--	8		GD08C-0450	6	81	43	36	36		○		
4.6	0.1811	--	3	External coolant	GD03-0460	6	66	24	17	36	M5×0.8	●		
	0.1811	--	5		GD05-0460	6	74	36	29	36		●		
	0.1811	--	3	Internal coolant	GD03C-0460	6	66	24	17	36		●		
	0.1811	--	5		GD05C-0460	6	74	36	29	36		●		
	0.1811	--	8		GD08C-0460	6	81	43	36	36		○		
4.65	0.1831	--	3	External coolant	GD03-0465	6	66	24	17	36	M5×0.8	●		
	0.1831	--	5		GD05-0465	6	74	36	29	36		●		
	0.1831	--	3	Internal coolant	GD03C-0465	6	66	24	17	36		●		
	0.1831	--	5		GD05C-0465	6	74	36	29	36		●		

Note: For drilling depth (l/d) of 8, namely GD08C series, tolerance of shank diameter is h₈.

● Stock available ○ Make-to-order



▶ Applicable material table

◎ Very suitable ○ Suitable

Grade	Workpiece material										
	Mild steel HB ≤ 180	Carbon steel, Alloy steel	Pre-hardened steel, Hardened steel			Stainless steel	Cast iron	Nodular cast iron	Aluminum alloy	Copper alloy	Heat resistant alloy
			~40HRC	~50HRC	~60HRC						
KDG3013	○	◎	◎			○	◎	◎			○

GD series universal machining

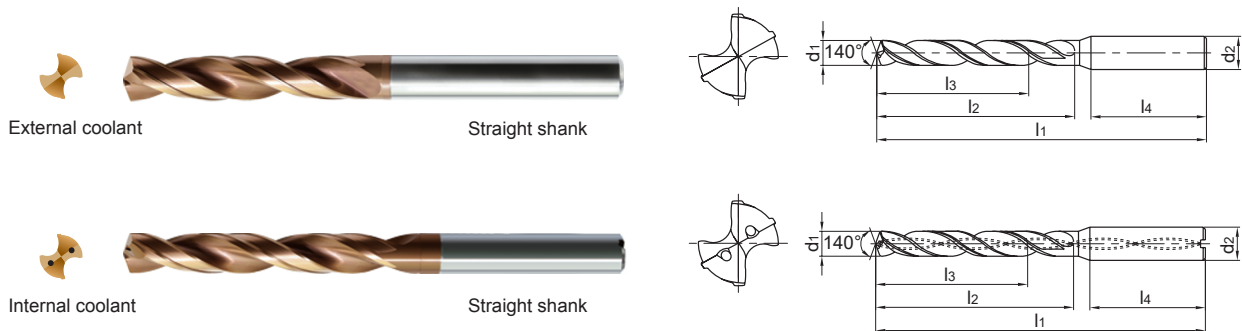

● Suitable for high efficiency drilling in a variety of materials e.g steel, stainless steel, cast iron.

Drill diameter d ₁ (m ₇)			Drilling depth (l/d)	Cooling mode	Shank type	Type	Basic dimension(mm)					Suitable for thread		Grade
mm	inch	Fraction					Shank diameter	Overall length	Flute length	Recommended drilling depth	Shank length	cutting taps / tread milling cutters	forming taps	
							d ₂ (h ₆)	l ₁	l ₂	l ₃	l ₄			KDG3013
4.7	0.1850	--	3	External coolant	Straight shank	GD03-0470	6	66	24	17	36	NO.12-28UNF		●
	0.1850	--	5			GD05-0470	6	74	36	29	36			●
	0.1850	--	3	Internal coolant		GD03C-0470	6	66	24	17	36			●
	0.1850	--	5			GD05C-0470	6	74	36	29	36			●
	0.1850	--	8			GD08C-0470	6	81	43	36	36			○
4.763	0.1875	3/16	3	External coolant		GD03-04763	6	66	24	17	36			●
	0.1875	3/16	5			GD05-04763	6	74	36	29	36		●	
	0.1875	3/16	3	Internal coolant		GD03C-04763	6	66	24	17	36			●
	0.1875	3/16	5			GD05C-04763	6	74	36	29	36		●	
4.8	0.1890	--	3	External coolant		GD03-0480	6	66	28	20	36			●
	0.1890	--	5		GD05-0480	6	82	44	35	36		●		
	0.1890	--	3	Internal coolant	GD03C-0480	6	66	28	20	36		M5×0.5	●	
	0.1890	--	5		GD05C-0480	6	82	44	35	36		●		
	0.1890	--	8		GD08C-0480	6	95	57	48	36		○		
4.9	0.1929	--	3	External coolant	GD03-0490	6	66	28	20	36			●	
	0.1929	--	5		GD05-0490	6	82	44	35	36		●		
	0.1929	--	3	Internal coolant	GD03C-0490	6	66	28	20	36			●	
	0.1929	--	5		GD05C-0490	6	82	44	35	36		●		
	0.1929	--	8		GD08C-0490	6	95	57	48	36		○		
5.0	0.1969	--	3	External coolant	GD03-0500	6	66	28	20	36			●	
	0.1969	--	5		GD05-0500	6	82	44	35	36		●		
	0.1969	--	3	Internal coolant	GD03C-0500	6	66	28	20	36	M6×1	NO.12-24UNC	●	
	0.1969	--	5		GD05C-0500	6	82	44	35	36		●		
	0.1969	--	8		GD08C-0500	6	95	57	48	36		○		
5.1	0.2008	--	3	External coolant	GD03-0510	6	66	28	20	36			●	
	0.2008	--	5		GD05-0510	6	82	44	35	36		●		
	0.2008	--	3	Internal coolant	GD03C-0510	6	66	28	20	36	1/4-20UNC	NO.12-28UNF	●	
	0.2008	--	5		GD05C-0510	6	82	44	35	36		●		
	0.2008	--	8		GD08C-0510	6	95	57	48	36		○		

● Stock available ○ Make-to-order

Drill diameter d ₁ (mm)			Drilling depth (l/d)	Cooling mode	Shank type	Type	Basic dimension(mm)					Suitable for thread		Grade		
mm	inch	Fraction					Shank diameter d ₂ (h ₆)	Overall length l ₁	Flute length l ₂	Recommended drilling depth l ₃	Shank length l ₄	cutting taps / tread milling cutters	forming taps			
5.2	0.2047	--	3	External coolant	Straight shank	GD03-0520	6	66	28	20	36	M6×0.75		●		
	0.2047	--	5			GD05-0520	6	82	44	35	36			●		
	0.2047	--	3	Internal coolant		GD03C-0520	6	66	28	20	36			●		
	0.2047	--	5			GD05C-0520	6	82	44	35	36			●		
	0.2047	--	8			GD08C-0520	6	95	57	48	36			○		
5.25	0.2067	--	3	External coolant		GD03-0525	6	66	28	20	36			M6×0.75		●
	0.2067	--	5			GD05-0525	6	82	44	35	36					●
	0.2067	--	3	Internal coolant		GD03C-0525	6	66	28	20	36					●
	0.2067	--	5			GD05C-0525	6	82	44	35	36					●
5.3	0.2087	--	3	External coolant		GD03-0530	6	66	28	20	36			M6×0.75		●
	0.2087	--	5		GD05-0530	6	82	44	35	36	●					
	0.2087	--	3	Internal coolant	GD03C-0530	6	66	28	20	36	●					
	0.2087	--	5		GD05C-0530	6	82	44	35	36	●					
5.4	0.2126	--	3	External coolant	GD03-0540	6	66	28	20	36	M6×0.75		●			
	0.2126	--	5		GD05-0540	6	82	44	35	36			●			
	0.2126	--	3	Internal coolant	GD03C-0540	6	66	28	20	36			●			
	0.2126	--	5		GD05C-0540	6	82	44	35	36			●			
	0.2126	--	8		GD08C-0540	6	95	57	48	36			○			
5.5	0.2165	--	3	External coolant	GD03-0550	6	66	28	20	36	1/4-28UNF		●			
	0.2165	--	5		GD05-0550	6	82	44	35	36			●			
	0.2165	--	3	Internal coolant	GD03C-0550	6	66	28	20	36			●			
	0.2165	--	5		GD05C-0550	6	82	44	35	36			●			
	0.2165	--	8		GD08C-0550	6	95	57	48	36			○			
5.558	0.2188	7/32	3	External coolant	GD03-05558	6	66	28	20	36	M6×1		●			
	0.2188	7/32	5		GD05-05558	6	82	44	35	36			●			
	0.2188	7/32	3	Internal coolant	GD03C-05558	6	66	28	20	36			●			
	0.2188	7/32	5		GD05C-05558	6	82	44	35	36			●			
5.6	0.2205	--	3	External coolant	GD03-0560	6	66	28	20	36	M6×1		●			
	0.2205	--	5		GD05-0560	6	82	44	35	36			●			
	0.2205	--	3	Internal coolant	GD03C-0560	6	66	28	20	36			●			
	0.2205	--	5		GD05C-0560	6	82	44	35	36			●			
	0.2205	--	8		GD08C-0560	6	95	57	48	36			○			

Note: For drilling depth (l/d) of 8 ,namely GD08C series, tolerance of shank diameter is h₈.

● Stock available ○ Make-to-order

▶▶ Applicable material table

◎ Very suitable ○ Suitable

Grade	Workpiece material										
	Mild steel HB ≤ 180	Carbon steel, Alloy steel	Pre-hardened steel, Hardened steel			Stainless steel	Cast iron	Nodular cast iron	Aluminum alloy	Copper alloy	Heat resistant alloy
			~40HRC	~50HRC	~60HRC						
KDG3013	○	◎	◎			○	◎	◎			○

GD series universal machining

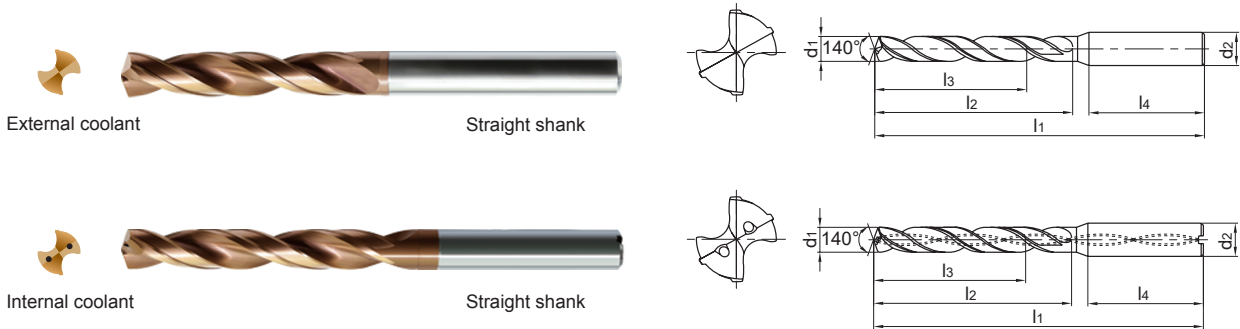

● Suitable for high efficiency drilling in a variety of materials e.g steel, stainless steel, cast iron.

Drill diameter d ₁ (m ₇)			Drilling depth (l/d)	Cooling mode	Shank type	Type	Basic dimension(mm)					Suitable for thread		Grade	
mm	inch	Fraction					Shank diameter	Overall length	Flute length	Recommended drilling depth	Shank length	cutting taps / tread milling cutters	forming taps		
									d ₂ (h ₆)	l ₁	l ₂	l ₃	l ₄		
5.7	0.2244	--	3	External coolant	Straight shank	GD03-0570	6	66	28	20	36	M6×0.75	●		
			5			GD05-0570	6	82	44	35	36		●		
	3	Internal coolant	GD03C-0570	6		66	28	20	36	●					
	5		GD05C-0570	6		82	44	35	36	●					
	8		GD08C-0570	6		95	57	48	36	○					
5.75	0.2264	--	3	External coolant		GD03-0575	6	66	28	20	36	1/4-20UNC	●		
			5			GD05-0575	6	82	44	35	36		●		
	3	Internal coolant	GD03C-0575	6		66	28	20	36	●					
	5		GD05C-0575	6		82	44	35	36	●					
5.8	0.2283	--	3	External coolant		GD03-0580	6	66	28	20	36		●		
			5		GD05-0580	6	82	44	35	36	●				
	3	Internal coolant	GD03C-0580	6	66	28	20	36	●						
	5		GD05C-0580	6	82	44	35	36	●						
	8		GD08C-0580	6	95	57	48	36	○						
5.9	0.2323	--	3	External coolant	GD03-0590	6	66	28	20	36		●			
			5		GD05-0590	6	82	44	35	36		●			
	3	Internal coolant	GD03C-0590	6	66	28	20	36	●						
	5		GD05C-0590	6	82	44	35	36	●						
	8		GD08C-0590	6	95	57	48	36	○						
5.95	0.2343	--	3	External coolant	GD03-0595	6	66	28	20	36	1/4-28UNF	●			
			5		GD05-0595	6	82	44	35	36		●			
	3	Internal coolant	GD03C-0595	6	66	28	20	36	●						
	5		GD05C-0595	6	82	44	35	36	●						
6.0	0.2362	--	3	External coolant	GD03-0600	6	66	28	20	36	M7×1	●			
			5		GD05-0600	6	82	44	35	36		●			
	3	Internal coolant	GD03C-0600	6	66	28	20	36	●						
	5		GD05C-0600	6	82	44	35	36	●						
	8		GD08C-0600	6	95	57	48	36	○						

● Stock available ○ Make-to-order

Drill diameter d ₁ (m7)			Drilling depth (l/d)	Cooling mode	Shank type	Type	Basic dimension(mm)					Suitable for thread		Grade
mm	inch	Fraction					Shank diameter d ₂ (h ₆)	Overall length l ₁	Flute length l ₂	Recommended drilling depth l ₃	Shank length l ₄	cutting taps / tread milling cutters	forming taps	
6.1	0.2402	--	3	External coolant	Straight shank	GD03-0610	8	79	34	24	36			●
	0.2402	--	5			GD05-0610	8	91	53	43	36			●
	0.2402	--	3	GD03C-0610		8	79	34	24	36			●	
	0.2402	--	5	GD05C-0610		8	91	53	43	36			●	
	0.2402	--	8	GD08C-0610		8	114	76	66	36			○	
6.2	0.2441	--	3	External coolant		GD03-0620	8	79	34	24	36			●
	0.2441	--	5			GD05-0620	8	91	53	43	36			●
	0.2441	--	3	Internal coolant		GD03C-0620	8	79	34	24	36			●
	0.2441	--	5			GD05C-0620	8	91	53	43	36			●
	0.2441	--	8			GD08C-0620	8	114	76	66	36			○
6.3	0.2480	--	3	External coolant	GD03-0630	8	79	34	24	36			●	
	0.2480	--	5		GD05-0630	8	91	53	43	36			●	
	0.2480	--	3	Internal coolant	GD03C-0630	8	79	34	24	36			●	
	0.2480	--	5		GD05C-0630	8	91	53	43	36			●	
	0.2480	--	8		GD08C-0630	8	114	76	66	36			○	
6.35	0.2500	1/4	3	External coolant	GD03-06350	8	79	34	24	36			●	
	0.2500	1/4	5		GD05-06350	8	91	53	43	36			●	
	0.2500	1/4	3	Internal coolant	GD03C-06350	8	79	34	24	36			●	
	0.2500	1/4	5		GD05C-06350	8	91	53	43	36			●	
6.4	0.2520	--	3	External coolant	GD03-0640	8	79	34	24	36			●	
	0.2520	--	5		GD05-0640	8	91	53	43	36			●	
	0.2520	--	3	Internal coolant	GD03C-0640	8	79	34	24	36			●	
	0.2520	--	5		GD05C-0640	8	91	53	43	36			●	
	0.2520	--	8		GD08C-0640	8	114	76	66	36			○	
6.5	0.2559	--	3	External coolant	GD03-0650	8	79	34	24	36			●	
	0.2559	--	5		GD05-0650	8	91	53	43	36			●	
	0.2559	--	3	Internal coolant	GD03C-0650	8	79	34	24	36			●	
	0.2559	--	5		GD05C-0650	8	91	53	43	36			●	
	0.2559	--	8		GD08C-0650	8	114	76	66	36			○	
6.6	0.2598	--	3	External coolant	GD03-0660	8	79	34	24	36	5/16-18UNC	M7×1	●	
	0.2598	--	5		GD05-0660	8	91	53	43	36			●	

Note: For drilling depth (l/d) of 8, namely GD08C series, tolerance of shank diameter is h₈.

● Stock available ○ Make-to-order



▶ Applicable material table

◎ Very suitable ○ Suitable

Grade	Workpiece material										
	Mild steel HB ≤ 180	Carbon steel, Alloy steel	Pre-hardened steel, Hardened steel			Stainless steel	Cast iron	Nodular cast iron	Aluminum alloy	Copper alloy	Heat resistant alloy
			~40HRC	~50HRC	~60HRC						
KDG3013	○	◎	◎			○	◎	◎			○

GD series universal machining

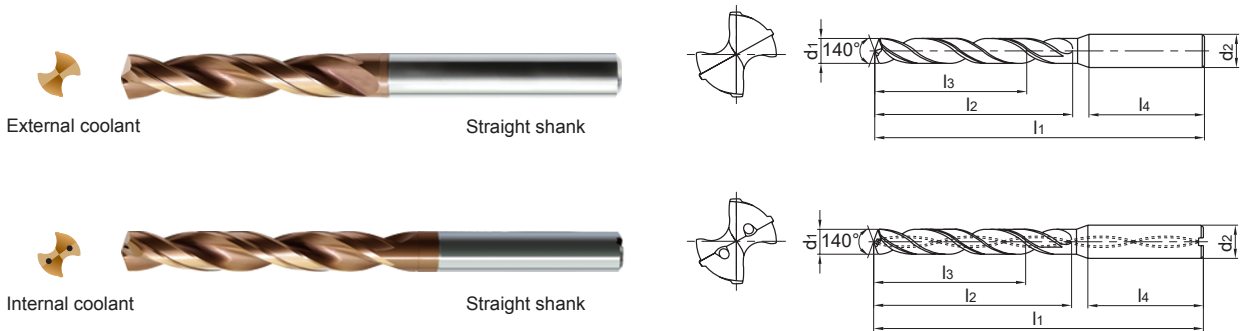

● Suitable for high efficiency drilling in a variety of materials e.g steel, stainless steel, cast iron.

Drill diameter d ₁ (m ₇)			Drilling depth (l/d)	Cooling mode	Shank type	Type	Basic dimension(mm)					Suitable for thread		Grade	
mm	inch	Fraction					Shank diameter	Overall length	Flute length	Recommended drilling depth	Shank length	cutting taps / tread milling cutters	forming taps		
							d ₂ (h ₆)	l ₁	l ₂	l ₃	l ₄			KDG3013	
6.6	0.2598	--	3	Internal coolant	Straight shank	GD03C-0660	8	79	34	24	36	5/16-18UNC	M7×1	●	
	0.2598	--	5			GD05C-0660	8	91	53	43	36			●	
	0.2598	--	8	GD08C-0660		8	114	76	66	36	○				
6.7	0.2638	--	3	External coolant		GD03-0670	8	79	34	24	36				●
	0.2638	--	5			GD05-0670	8	91	53	43	36				●
	0.2638	--	3	Internal coolant		GD03C-0670	8	79	34	24	36				●
	0.2638	--	5			GD05C-0670	8	91	53	43	36				●
	0.2638	--	8	GD08C-0670		8	114	76	66	36	○				
	6.746	0.2656	17/64	3		External coolant	GD03-06746	8	79	34	24				36
0.2656		17/64	5	GD05-06746			8	91	53	43	36	●			
0.2656		17/64	3	Internal coolant		GD03C-06746	8	79	34	24	36	●			
0.2656		17/64	5			GD05C-06746	8	91	53	43	36	●			
6.8	0.2677	--	3	External coolant	GD03-0680	8	79	34	24	36				●	
	0.2677	--	5		GD05-0680	8	91	53	43	36				●	
	0.2677	--	3	Internal coolant	GD03C-0680	8	79	34	24	36				●	
	0.2677	--	5		GD05C-0680	8	91	53	43	36				●	
	0.2677	--	8		GD08C-0680	8	114	76	66	36				○	
6.9	0.2717	--	3	External coolant	GD03-0690	8	79	34	24	36	5/16-24UNF			●	
	0.2717	--	5		GD05-0690	8	91	53	43	36				●	
	0.2717	--	3	Internal coolant	GD03C-0690	8	79	34	24	36				●	
	0.2717	--	5		GD05C-0690	8	91	53	43	36				●	
	0.2717	--	8		GD08C-0690	8	114	76	66	36				○	
7.0	0.2756	--	3	External coolant	GD03-0700	8	79	34	24	36	M8×1			●	
	0.2756	--	5		GD05-0700	8	91	53	43	36				●	
	0.2756	--	3	Internal coolant	GD03C-0700	8	79	34	24	36				●	
	0.2756	--	5		GD05C-0700	8	91	53	43	36				●	
	0.2756	--	8		GD08C-0700	8	116	76	66	36				○	
7.1	0.2795	--	3	External coolant	GD03-0710	8	79	41	29	36				●	
	0.2795	--	5		GD05-0710	8	91	53	43	36				●	

● Stock available ○ Make-to-order

Drill diameter d ₁ (mm)			Drilling depth (l/d)	Cooling mode	Shank type	Type	Basic dimension(mm)					Suitable for thread		Grade
mm	inch	Fraction					Shank diameter d ₂ (h ₆)	Overall length l ₁	Flute length l ₂	Recommended drilling depth l ₃	Shank length l ₄	cutting taps / tread milling cutters	forming taps	
7.1	0.2795	--	3	Internal coolant	Straight shank	GD03C-0710	8	79	41	29	36			●
	0.2795	--	5			GD05C-0710	8	91	53	43	36			●
	0.2795	--	8			GD08C-0710	8	116	76	66	36			○
7.145	0.2813	9/32	3	External coolant		GD03-07145	8	79	41	29	36			●
	0.2813	9/32	5			GD05-07145	8	91	53	43	36			●
	0.2813	9/32	3	Internal coolant		GD03C-07145	8	79	41	29	36			●
	0.2813	9/32	5			GD05C-07145	8	91	53	43	36			●
7.2	0.2835	--	3	External coolant		GD03-0720	8	79	41	29	36			●
	0.2835	--	5			GD05-0720	8	91	53	43	36			●
	0.2835	--	3	Internal coolant		GD03C-0720	8	79	41	29	36			●
	0.2835	--	5			GD05C-0720	8	91	53	43	36			●
	0.2835	--	8			GD08C-0720	8	116	76	66	36			○
7.3	0.2874	--	3	External coolant	GD03-0730	8	79	41	29	36			●	
	0.2874	--	5		GD05-0730	8	91	53	43	36			●	
	0.2874	--	3	Internal coolant	GD03C-0730	8	79	41	29	36		5/16-18UNC	●	
	0.2874	--	5		GD05C-0730	8	91	53	43	36			●	
	0.2874	--	8		GD08C-0730	8	116	76	66	36			○	
7.4	0.2913	--	3	External coolant	GD03-0740	8	79	41	29	36			●	
	0.2913	--	5		GD05-0740	8	91	53	43	36			●	
	0.2913	--	3	Internal coolant	GD03C-0740	8	79	41	29	36			●	
	0.2913	--	5		GD05C-0740	8	91	53	43	36			●	
	0.2913	--	8		GD08C-0740	8	116	76	66	36			○	
7.45	0.2933	--	3	External coolant	GD03-0745	8	79	41	29	36			●	
	0.2933	--	5		GD05-0745	8	91	53	43	36		M8×1.25	●	
	0.2933	--	3	Internal coolant	GD03C-0745	8	79	41	29	36		5/16-24UNF	●	
	0.2933	--	5		GD05C-0745	8	91	53	43	36			●	
7.5	0.2953	--	3	External coolant	GD03-0750	8	79	41	29	36			●	
	0.2953	--	5		GD05-0750	8	91	53	43	36			●	
	0.2953	--	3	Internal coolant	GD03C-0750	8	79	41	29	36			●	
	0.2953	--	5		GD05C-0750	8	91	53	43	36			●	
	0.2953	--	8		GD08C-0750	8	116	76	66	36			○	

Note: For drilling depth (l/d) of 8, namely GD08C series, tolerance of shank diameter is h₈.

● Stock available ○ Make-to-order

▶ Applicable material table

◎ Very suitable ○ Suitable

Grade	Workpiece material										
	Mild steel HB ≤ 180	Carbon steel, Alloy steel	Pre-hardened steel, Hardened steel			Stainless steel	Cast iron	Nodular cast iron	Aluminum alloy	Copper alloy	Heat resistant alloy
			~40HRC	~50HRC	~60HRC						
KDG3013	○	◎	◎			○	◎	◎			○

GD series universal machining

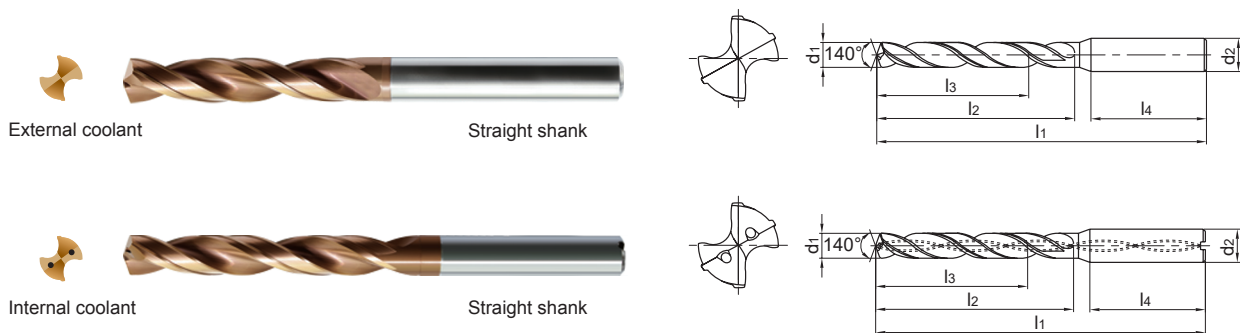

● Suitable for high efficiency drilling in a variety of materials e.g steel, stainless steel, cast iron.

Drill diameter $d_1(m_7)$			Drilling depth (l/d)	Cooling mode	Shank type	Type	Basic dimension(mm)					Suitable for thread		Grade
mm	inch	Fraction					Shank diameter $d_2(h_6)$	Overall length l_1	Flute length l_2	Recommended drilling depth l_3	Shank length l_4	cutting taps / tread milling cutters	forming taps	
7.541	0.2969	19/64	3	External coolant	Straight shank	GD03-07541	8	79	41	29	36			●
	0.2969	19/64	5			GD05-07541	8	91	53	43	36			●
	0.2969	19/64	3	Internal coolant		GD03C-07541	8	79	41	29	36			●
	0.2969	19/64	5			GD05C-07541	8	91	53	43	36			●
7.6	0.2992	--	3	External coolant		GD03-0760	8	79	41	29	36			●
	0.2992	--	5			GD05-0760	8	91	53	43	36			●
	0.2992	--	3	Internal coolant		GD03C-0760	8	79	41	29	36		M8×1	●
	0.2992	--	5			GD05C-0760	8	91	53	43	36			●
	0.2992	--	8			GD08C-0760	8	116	76	66	36			○
7.7	0.3031	--	3	External coolant		GD03-0770	8	79	41	29	36			●
	0.3031	--	5			GD05-0770	8	91	53	43	36			●
	0.3031	--	3	Internal coolant		GD03C-0770	8	79	41	29	36			●
	0.3031	--	5		GD05C-0770	8	91	53	43	36			●	
	0.3031	--	8		GD08C-0770	8	116	76	66	36		○		
7.8	0.3071	--	3	External coolant	GD03-0780	8	79	41	29	36			●	
	0.3071	--	5		GD05-0780	8	91	53	43	36			●	
	0.3071	--	3	Internal coolant	GD03C-0780	8	79	41	29	36			●	
	0.3071	--	5		GD05C-0780	8	91	53	43	36			●	
	0.3071	--	8		GD08C-0780	8	116	76	66	36		○		
7.9	0.3110	--	3	External coolant	GD03-0790	8	79	41	29	36			●	
	0.3110	--	5		GD05-0790	8	91	53	43	36			●	
	0.3110	--	3	Internal coolant	GD03C-0790	8	79	41	29	36			●	
	0.3110	--	5		GD05C-0790	8	91	53	43	36			●	
	0.3110	--	8		GD08C-0790	8	116	76	66	36		○		
7.938	0.3125	5/16	3	External coolant	GD03-07938	8	79	41	29	36			●	
	0.3125	5/16	5		GD05-07938	8	91	53	43	36			●	
	0.3125	5/16	3	Internal coolant	GD03C-07938	8	79	41	29	36			●	
	0.3125	5/16	5		GD05C-07938	8	91	53	43	36			●	

● Stock available ○ Make-to-order

Drill diameter d ₁ (m7)			Drilling depth (l/d)	Cooling mode	Shank type	Type	Basic dimension(mm)					Suitable for thread		Grade
mm	inch	Fraction					Shank diameter d ₂ (h ₆)	Overall length l ₁	Flute length l ₂	Recommended drilling depth l ₃	Shank length l ₄	cutting taps / tread milling cutters	forming taps	
8.0	0.3150	--	3	External coolant	Straight shank	GD03-0800	8	79	41	29	36	3/8-16UNC		●
	0.3150	--	5			GD05-0800	8	91	53	43	36			●
	0.3150	--	3	GD03C-0800		8	79	41	29	36	●			
	0.3150	--	5	GD05C-0800		8	91	53	43	36	●			
	0.3150	--	8	GD08C-0800		8	116	76	66	36	○			
8.1	0.3189	--	3	External coolant		GD03-0810	10	89	47	35	40			●
	0.3189	--	5			GD05-0810	10	103	61	49	40			●
	0.3189	--	3	GD03C-0810		10	89	47	35	40	●			
	0.3189	--	5	GD05C-0810		10	103	61	49	40	●			
	0.3189	--	8	GD08C-0810		10	142	95	83	40	○			
8.2	0.3228	--	3	External coolant	GD03-0820	10	89	47	35	40			●	
	0.3228	--	5		GD05-0820	10	103	61	49	40			●	
	0.3228	--	3	Internal coolant	GD03C-0820	10	89	47	35	40			●	
	0.3228	--	5		GD05C-0820	10	103	61	49	40			●	
	0.3228	--	8		GD08C-0820	10	142	95	83	40			○	
8.3	0.3268	--	3	External coolant	GD03-0830	10	89	47	35	40			●	
	0.3268	--	5		GD05-0830	10	103	61	49	40			●	
	0.3268	--	3	Internal coolant	GD03C-0830	10	89	47	35	40			●	
	0.3268	--	5		GD05C-0830	10	103	61	49	40			●	
	0.3268	--	8		GD08C-0830	10	142	95	83	40			○	
8.334	0.3281	21/64	3	External coolant	GD03-08334	10	89	47	35	40			●	
	0.3281	21/64	5		GD05-08334	10	103	61	49	40			●	
	0.3281	21/64	3	Internal coolant	GD03C-08334	10	89	47	35	40			●	
	0.3281	21/64	5		GD05C-08334	10	103	61	49	40			●	
8.4	0.3307	--	3	External coolant	GD03-0840	10	89	47	35	40			●	
	0.3307	--	5		GD05-0840	10	103	61	49	40			●	
	0.3307	--	3	Internal coolant	GD03C-0840	10	89	47	35	40			●	
	0.3307	--	5		GD05C-0840	10	103	61	49	40			●	
	0.3307	--	8		GD08C-0840	10	142	95	83	40			○	

Note: For drilling depth (l/d) of 8 ,namely GD08C series, tolerance of shank diameter is h₅.

● Stock available ○ Make-to-order



▶ Applicable material table

○ Very suitable ○ Suitable

Grade	Workpiece material										
	Mild steel HB ≤ 180	Carbon steel, Alloy steel	Pre-hardened steel, Hardened steel			Stainless steel	Cast iron	Nodular cast iron	Aluminum alloy	Copper alloy	Heat resistant alloy
			~40HRC	~50HRC	~60HRC						
KDG3013	○	○	○			○	○	○			○

GD series universal machining

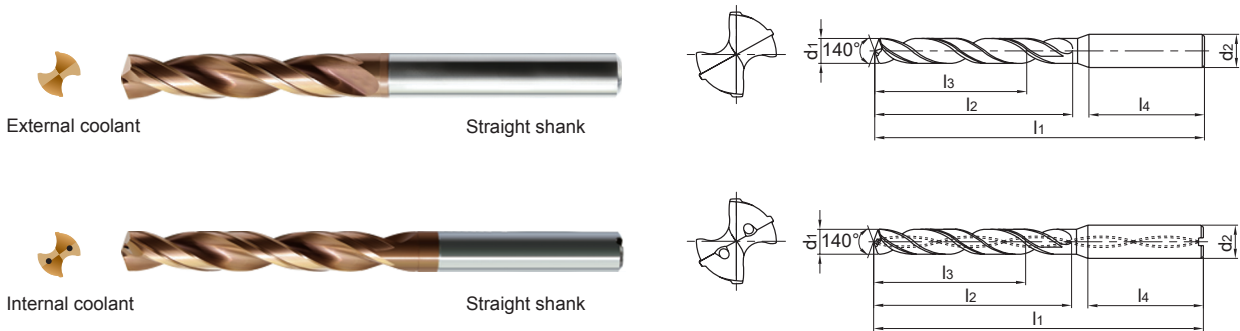

● Suitable for high efficiency drilling in a variety of materials e.g steel, stainless steel, cast iron.

Drill diameter d ₁ (m ₇)			Drilling depth (l/d)	Cooling mode	Shank type	Type	Basic dimension(mm)					Suitable for thread		Grade
mm	inch	Fraction					Shank diameter	Overall length	Flute length	Recommended drilling depth	Shank length	cutting taps / tread milling cutters	forming taps	
							d ₂ (h ₆)	l ₁	l ₂	l ₃	l ₄			KDG3013
8.5	0.3346	--	3	External coolant	Straight shank	GD03-0850	10	89	47	35	40	M10×1.5 3/8-24UNF		●
			5			GD05-0850	10	103	61	49	40		●	
	3	GD03C-0850	10	89		47	35	40	●					
	5	GD05C-0850	10	103		61	49	40	●					
	8	GD08C-0850	10	142		95	83	40	○					
8.6	0.3386	--	3	External coolant		GD03-0860	10	89	47	35	40		●	
			5			GD05-0860	10	103	61	49	40	●		
	3	GD03C-0860	10	89		47	35	40	●					
	5	GD05C-0860	10	103		61	49	40	●					
	8	GD08C-0860	10	142		95	83	40	○					
8.7	0.3425	--	3	External coolant	GD03-0870	10	89	47	35	40		●		
			5		GD05-0870	10	103	61	49	40	●			
	3	GD03C-0870	10	89	47	35	40	●						
	5	GD05C-0870	10	103	61	49	40	●						
	8	GD08C-0870	10	142	95	83	40	○						
8.733	0.3438	11/32	3	External coolant	GD03-08733	10	89	47	35	40		●		
			5		GD05-08733	10	103	61	49	40	●			
	3	GD03C-08733	10	89	47	35	40	●						
	5	GD05C-08733	10	103	61	49	40	●						
8.8	0.3465	--	3	External coolant	GD03-0880	10	89	47	35	40		●		
			5		GD05-0880	10	103	61	49	40	●			
	3	GD03C-0880	10	89	47	35	40	3/8-16UNC	●					
	5	GD05C-0880	10	103	61	49	40	●						
	8	GD08C-0880	10	142	95	83	40	○						
8.9	0.3504	--	3	External coolant	GD03-0890	10	89	47	35	40		●		
			5		GD05-0890	10	103	61	49	40	●			
	3	GD03C-0890	10	89	47	35	40	●						
	5	GD05C-0890	10	103	61	49	40	●						
	8	GD08C-0890	10	142	95	83	40	○						

● Stock available ○ Make-to-order

Drill diameter d ₁ (m ₇)			Drilling depth (l/d)	Cooling mode	Shank type	Type	Basic dimension(mm)					Suitable for thread		Grade
mm	inch	Fraction					Shank diameter	Overall length	Flute length	Recommended drilling depth	Shank length	cutting taps / tread milling cutters	forming taps	
9.0	0.3543	--	3	External coolant	Straight shank	GD03-0900	10	89	47	35	40	M10×1	3/8-24UNF	●
	0.3543	--	5			GD05-0900	10	103	61	49	40			●
	0.3543	--	3	Internal coolant		GD03C-0900	10	89	47	35	40			●
	0.3543	--	5			GD05C-0900	10	103	61	49	40			●
	0.3543	--	8			GD08C-0900	10	142	95	83	40			○
9.1	0.3583	--	3	External coolant		GD03-0910	10	89	47	35	40			●
	0.3583	--	5			GD05-0910	10	103	61	49	40			●
	0.3583	--	3	Internal coolant		GD03C-0910	10	89	47	35	40			●
	0.3583	--	5			GD05C-0910	10	103	61	49	40			●
	0.3583	--	8			GD08C-0910	10	142	95	83	40			○
9.129	0.3594	23/64	3	External coolant	GD03-09129	10	89	47	35	40			●	
	0.3594	23/64	5		GD05-09129	10	103	61	49	40			●	
	0.3594	23/64	3	Internal coolant	GD03C-09129	10	89	47	35	40			●	
	0.3594	23/64	5		GD05C-09129	10	103	61	49	40			●	
9.2	0.3622	--	3	External coolant	GD03-0920	10	89	47	35	40			●	
	0.3622	--	5		GD05-0920	10	103	61	49	40			●	
	0.3622	--	3	Internal coolant	GD03C-0920	10	89	47	35	40			●	
	0.3622	--	5		GD05C-0920	10	103	61	49	40			●	
	0.3622	--	8		GD08C-0920	10	142	95	83	40			○	
9.3	0.3661	--	3	External coolant	GD03-0930	10	89	47	35	40			●	
	0.3661	--	5		GD05-0930	10	103	61	49	40			●	
	0.3661	--	3	Internal coolant	GD03C-0930	10	89	47	35	40			●	
	0.3661	--	5		GD05C-0930	10	103	61	49	40			●	
	0.3661	--	8		GD08C-0930	10	142	95	83	40			○	
9.35	0.3681	--	3	External coolant	GD03-0935	10	89	47	35	40	M10×1.5		●	
	0.3681	--	5		GD05-0935	10	103	61	49	40			●	
	0.3681	--	3	Internal coolant	GD03C-0935	10	89	47	35	40			●	
	0.3681	--	5		GD05C-0935	10	103	61	49	40			●	
9.4	0.3701	--	3	External coolant	GD03-0940	10	89	47	35	40	7/16-14UNC		●	
	0.3701	--	5		GD05-0940	10	103	61	49	40			●	
	0.3701	--	3	Internal coolant	GD03C-0940	10	89	47	35	40			●	
	0.3701	--	5		GD05C-0940	10	103	61	49	40			●	
	0.3701	--	8		GD08C-0940	10	142	95	83	40			○	

Note: For drilling depth (l/d) of 8 ,namely GD08C series, tolerance of shank diameter is h₈.

● Stock available ○ Make-to-order

Applicable material table

◎ Very suitable ○ Suitable

Grade	Workpiece material										
	Mild steel HB ≤ 180	Carbon steel, Alloy steel	Pre-hardened steel, Hardened steel			Stainless steel	Cast iron	Nodular cast iron	Aluminum alloy	Copper alloy	Heat resistant alloy
			~40HRC	~50HRC	~60HRC						
KDG3013	○	◎	◎			○	◎	◎			○

GD series universal machining

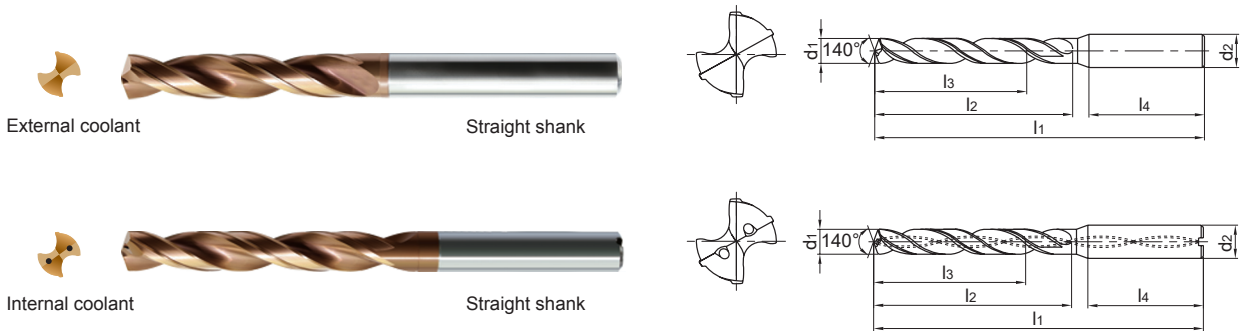

● Suitable for high efficiency drilling in a variety of materials e.g steel, stainless steel, cast iron.

Drill diameter d ₁ (m ₇)			Drilling depth (l/d)	Cooling mode	Shank type	Type	Basic dimension(mm)					Suitable for thread		Grade
mm	inch	Fraction					Shank diameter	Overall length	Flute length	Recommended drilling depth	Shank length	cutting taps / tread milling cutters	forming taps	
							d ₂ (h ₆)	l ₁	l ₂	l ₃	l ₄			KDG3013
9.45	0.3720	--	3	External coolant	Straight shank	GD03-0945	10	89	47	35	40	M10×1.25	●	
	0.3720	--	5			GD05-0945	10	103	61	49	40		●	
	0.3720	--	3	Internal coolant		GD03C-0945	10	89	47	35	40		●	
	0.3720	--	5			GD05C-0945	10	103	61	49	40		●	
9.5	0.3740	--	3	External coolant		GD03-0950	10	89	47	35	40	M10×1	●	
	0.3740	--	5			GD05-0950	10	103	61	49	40		●	
	0.3740	--	3	Internal coolant		GD03C-0950	10	89	47	35	40		●	
	0.3740	--	5			GD05C-0950	10	103	61	49	40		●	
	0.3740	--	8		GD08C-0950	10	142	95	83	40	○			
9.525	0.3750	3/8	3	External coolant	GD03-09525	10	89	47	35	40	M10×1	●		
	0.3750	3/8	5		GD05-09525	10	103	61	49	40		●		
	0.3750	3/8	3	Internal coolant	GD03C-09525	10	89	47	35	40		●		
	0.3750	3/8	5		GD05C-09525	10	103	61	49	40		●		
9.6	0.3780	--	3	External coolant	GD03-0960	10	89	47	35	40	M10×1	●		
	0.3780	--	5		GD05-0960	10	103	61	49	40		●		
	0.3780	--	3	Internal coolant	GD03C-0960	10	89	47	35	40		●		
	0.3780	--	5		GD05C-0960	10	103	61	49	40		●		
	0.3780	--	8		GD08C-0960	10	142	95	83	40		○		
9.7	0.3819	--	3	External coolant	GD03-0970	10	89	47	35	40	M10×1	●		
	0.3819	--	5		GD05-0970	10	103	61	49	40		●		
	0.3819	--	3	Internal coolant	GD03C-0970	10	89	47	35	40		●		
	0.3819	--	5		GD05C-0970	10	103	61	49	40		●		
	0.3819	--	8		GD08C-0970	10	142	95	83	40		○		
9.8	0.3858	--	3	External coolant	GD03-0980	10	89	47	35	40	M10×1	●		
	0.3858	--	5		GD05-0980	10	103	61	49	40		●		
	0.3858	--	3	Internal coolant	GD03C-0980	10	89	47	35	40		●		
	0.3858	--	5		GD05C-0980	10	103	61	49	40		●		
	0.3858	--	8		GD08C-0980	10	142	95	83	40		○		

● Stock available ○ Make-to-order

Drill diameter d ₁ (mm)			Drilling depth (l/d)	Cooling mode	Shank type	Type	Basic dimension(mm)					Suitable for thread		Grade
mm	inch	Fraction					Shank diameter d ₂ (h ₆)	Overall length l ₁	Flute length l ₂	Recommended drilling depth l ₃	Shank length l ₄	cutting taps / tread milling cutters	forming taps	
9.9	0.3898	--	3	External coolant	Straight shank	GD03-0990	10	89	47	35	40	7/16-20UNF		●
	0.3898	--	5			GD05-0990	10	103	61	49	40			●
	0.3898	--	3	Internal coolant		GD03C-0990	10	89	47	35	40			●
	0.3898	--	5			GD05C-0990	10	103	61	49	40			●
	0.3898	--	8			GD08C-0990	10	142	95	83	40			○
9.921	0.3906	25/64	3	External coolant		GD03-09921	10	89	47	35	40			●
	0.3906	25/64	5			GD05-09921	10	103	61	49	40			●
	0.3906	25/64	3	Internal coolant		GD03C-09921	10	89	47	35	40			●
	0.3906	25/64	5			GD05C-09921	10	103	61	49	40			●
10.0	0.3937	--	3	External coolant		GD03-1000	10	89	47	35	40			●
	0.3937	--	5		GD05-1000	10	103	61	49	40	●			
	0.3937	--	3	Internal coolant	GD03C-1000	10	89	47	35	40	●			
	0.3937	--	5		GD05C-1000	10	103	61	49	40	●			
10.1	0.3976	--	3	External coolant	GD03-1010	12	102	55	40	45			●	
	0.3976	--	5		GD05-1010	12	118	71	56	45			●	
	0.3976	--	3	Internal coolant	GD03C-1010	12	102	55	40	45			●	
	0.3976	--	5		GD05C-1010	12	118	71	56	45			●	
	0.3976	--	8		GD08C-1010	12	162	114	99	45			○	
10.2	0.4016	--	3	External coolant	GD03-1020	12	102	55	40	45			●	
	0.4016	--	5		GD05-1020	12	118	71	56	45			●	
	0.4016	--	3	Internal coolant	GD03C-1020	12	102	55	40	45			●	
	0.4016	--	5		GD05C-1020	12	118	71	56	45			●	
	0.4016	--	8		GD08C-1020	12	162	114	99	45			○	
10.25	0.4035	--	3	External coolant	GD03-1025	12	102	55	40	45	M12×1.75		●	
	0.4035	--	5		GD05-1025	12	118	71	56	45			●	
	0.4035	--	3	Internal coolant	GD03C-1025	12	102	55	40	45			●	
	0.4035	--	5		GD05C-1025	12	118	71	56	45			●	
10.3	0.4055	--	3	External coolant	GD03-1030	12	102	55	40	45	7/16-14UNC		●	
	0.4055	--	5		GD05-1030	12	118	71	56	45			●	
	0.4055	--	3	Internal coolant	GD03C-1030	12	102	55	40	45			●	
	0.4055	--	5		GD05C-1030	12	118	71	56	45			●	
	0.4055	--	8		GD08C-1030	12	162	114	99	45		○		

Note: For drilling depth (l/d) of 8 ,namely GD08C series, tolerance of shank diameter is h₈.

● Stock available ○ Make-to-order

Applicable material table

◎ Very suitable ○ Suitable

Grade	Workpiece material										
	Mild steel HB ≤ 180	Carbon steel, Alloy steel	Pre-hardened steel, Hardened steel			Stainless steel	Cast iron	Nodular cast iron	Aluminum alloy	Copper alloy	Heat resistant alloy
			~40HRC	~50HRC	~60HRC						
KDG3013	○	◎	◎			○	◎	◎			○

GD series universal machining

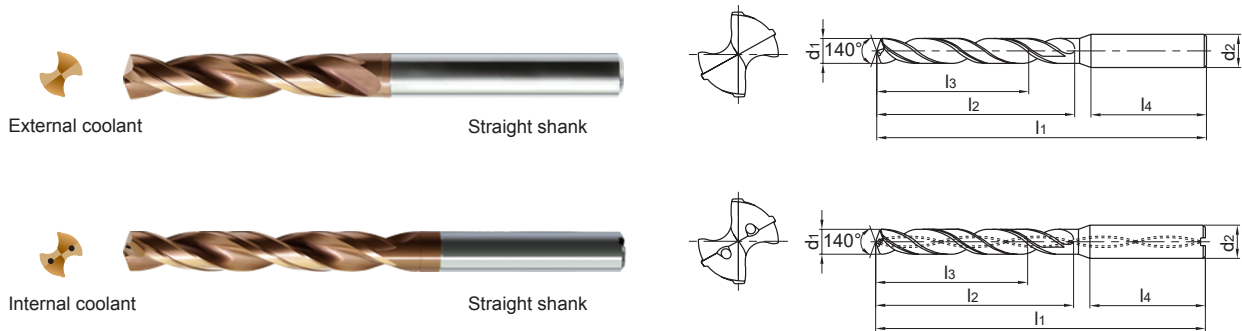

● Suitable for high efficiency drilling in a variety of materials e.g steel, stainless steel, cast iron.

Drill diameter d ₁ (m ₇)			Drilling depth (l/d)	Cooling mode	Shank type	Type	Basic dimension(mm)					Suitable for thread		Grade	
mm	inch	Fraction					Shank diameter d ₂ (h ₆)	Overall length l ₁	Flute length l ₂	Recommended drilling depth l ₃	Shank length l ₄	cutting taps / tread milling cutters	forming taps		
10.32	0.4063	13/32	3	External coolant	Straight shank	GD03-10320	12	102	55	40	45			●	
	0.4063	13/32	5			GD05-10320	12	118	71	56	45			●	
	0.4063	13/32	3	Internal coolant		GD03C-10320	12	102	55	40	45			●	
	0.4063	13/32	5			GD05C-10320	12	118	71	56	45			●	
10.4	0.4094	--	3	External coolant		GD03-1040	12	102	55	40	45			●	
	0.4094	--	5			GD05-1040	12	118	71	56	45			●	
	0.4094	--	3	Internal coolant		GD03C-1040	12	102	55	40	45			●	
	0.4094	--	5			GD05C-1040	12	118	71	56	45			●	
	0.4094	--	8			GD08C-1040	12	162	114	99	45			○	
10.5	0.4134	--	3	External coolant		GD03-1050	12	102	55	40	45			●	
	0.4134	--	5			GD05-1050	12	118	71	56	45			●	
	0.4134	--	3	Internal coolant		GD03C-1050	12	102	55	40	45	M12×1.5	7/16-20UNF	●	
	0.4134	--	5		GD05C-1050	12	118	71	56	45	●				
	0.4134	--	8		GD08C-1050	12	162	114	99	45	○				
10.6	0.4173	--	3	External coolant	GD03-1060	12	102	55	40	45					●
	0.4173	--	5		GD05-1060	12	118	71	56	45					●
	0.4173	--	3	Internal coolant	GD03C-1060	12	102	55	40	45			●		
	0.4173	--	5		GD05C-1060	12	118	71	56	45			●		
	0.4173	--	8		GD08C-1060	12	162	114	99	45			○		
10.7	0.4213	--	3	External coolant	GD03-1070	12	102	55	40	45			●		
	0.4213	--	5		GD05-1070	12	118	71	56	45			●		
	0.4213	--	3	Internal coolant	GD03C-1070	12	102	55	40	45			●		
	0.4213	--	5		GD05C-1070	12	118	71	56	45			●		
	0.4213	--	8		GD08C-1070	12	162	114	99	45			○		
10.716	0.4219	27/64	3	External coolant	GD03-10716	12	102	55	40	45			●		
	0.4219	27/64	5		GD05-10716	12	118	71	56	45			●		
	0.4219	27/64	3	Internal coolant	GD03C-10716	12	102	55	40	45			●		
	0.4219	27/64	5		GD05C-10716	12	118	71	56	45			●		

● Stock available ○ Make-to-order

Drill diameter d ₁ (m7)			Drilling depth (l/d)	Cooling mode	Shank type	Type	Basic dimension(mm)					Suitable for thread		Grade
mm	inch	Fraction					Shank diameter d ₂ (h ₆)	Overall length l ₁	Flute length l ₂	Recommended drilling depth l ₃	Shank length l ₄	cutting taps / tread milling cutters	forming taps	
10.75	0.4232	--	3	External coolant	Straight shank	GD03-1075	12	102	55	40	45	M12×1.25		●
	0.4232	--	5			GD05-1075	12	118	71	56	45			●
	0.4232	--	3	Internal coolant		GD03C-1075	12	102	55	40	45			●
	0.4232	--	5			GD05C-1075	12	118	71	56	45			●
10.8	0.4252	--	3	External coolant		GD03-1080	12	102	55	40	45	1/2-13UNC		●
	0.4252	--	5			GD05-1080	12	118	71	56	45			●
	0.4252	--	3	Internal coolant		GD03C-1080	12	102	55	40	45			●
	0.4252	--	5			GD05C-1080	12	118	71	56	45			●
10.9	0.4291	--	3	External coolant	GD03-1090	12	102	55	40	45			●	
	0.4291	--	5		GD05-1090	12	118	71	56	45			●	
	0.4291	--	3	Internal coolant	GD03C-1090	12	102	55	40	45			●	
	0.4291	--	5		GD05C-1090	12	118	71	56	45			●	
11.0	0.4331	--	3	External coolant	GD03-1100	12	102	55	40	45			●	
	0.4331	--	5		GD05-1100	12	118	71	56	45			●	
	0.4331	--	3	Internal coolant	GD03C-1100	12	102	55	40	45			●	
	0.4331	--	5		GD05C-1100	12	118	71	56	45			●	
11.1	0.4370	--	3	External coolant	GD03-1110	12	102	55	40	45			●	
	0.4370	--	5		GD05-1110	12	118	71	56	45			●	
	0.4370	--	3	Internal coolant	GD03C-1110	12	102	55	40	45			●	
	0.4370	--	5		GD05C-1110	12	118	71	56	45			●	
11.113	0.4375	7/16	3	External coolant	GD03-11113	12	102	55	40	45			●	
	0.4375	7/16	5		GD05-11113	12	118	71	56	45			●	
	0.4375	7/16	3	Internal coolant	GD03C-11113	12	102	55	40	45			●	
	0.4375	7/16	5		GD05C-11113	12	118	71	56	45			●	
11.2	0.4409	--	3	External coolant	GD03-1120	12	102	55	40	45			●	
	0.4409	--	5		GD05-1120	12	118	71	56	45			●	

Note: For drilling depth (l/d) of 8, namely GD08C series, tolerance of shank diameter is h₈.

● Stock available ○ Make-to-order



▶ Applicable material table

○ Very suitable ○ Suitable

Grade	Workpiece material										
	Mild steel HB ≤ 180	Carbon steel, Alloy steel	Pre-hardened steel, Hardened steel			Stainless steel	Cast iron	Nodular cast iron	Aluminum alloy	Copper alloy	Heat resistant alloy
			~40HRC	~50HRC	~60HRC						
KDG3013	○	○	○			○	○	○			○

GD series universal machining

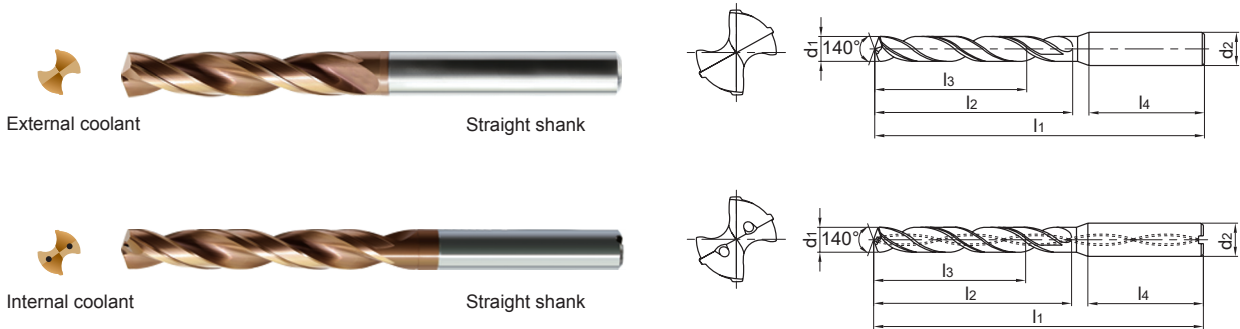

● Suitable for high efficiency drilling in a variety of materials e.g steel, stainless steel, cast iron.

Drill diameter d ₁ (m ₇)			Drilling depth (l/d)	Cooling mode	Shank type	Type	Basic dimension(mm)					Suitable for thread		Grade		
mm	inch	Fraction					Shank diameter	Overall length	Flute length	Recommended drilling depth	Shank length	cutting taps / tread milling cutters	forming taps		KDG3013	
									d ₂ (h ₆)	l ₁	l ₂	l ₃	l ₄			
11.2	0.4409	--	3	Internal coolant	Straight shank	GD03C-1120	12	102	55	40	45			●		
	0.4409	--	5			GD05C-1120	12	118	71	56	45			●		
	0.4409	--	8			GD08C-1120	12	162	114	99	45			○		
11.25	0.4429	--	3	External coolant		GD03-1125	12	102	55	40	45		M12×1.75	●		
	0.4429	--	5			GD05-1125	12	118	71	56	45			●		
	0.4429	--	3	Internal coolant		GD03C-1125	12	102	55	40	45			●		
	0.4429	--	5			GD05C-1125	12	118	71	56	45			●		
11.3	0.4449	--	3	External coolant		GD03-1130	12	102	55	40	45			●		
	0.4449	--	5			GD05-1130	12	118	71	56	45			●		
	0.4449	--	3	Internal coolant		GD03C-1130	12	102	55	40	45			●		
	0.4449	--	5			GD05C-1130	12	118	71	56	45			●		
	0.4449	--	8			GD08C-1130	12	162	114	99	45			○		
11.35	0.4469	--	3	External coolant	GD03-1135	12	102	55	40	45		M12×1.5	●			
	0.4469	--	5		GD05-1135	12	118	71	56	45			●			
	0.4469	--	3	Internal coolant	GD03C-1135	12	102	55	40	45			●			
	0.4469	--	5		GD05C-1135	12	118	71	56	45			●			
11.4	0.4488	--	3	External coolant	GD03-1140	12	102	55	40	45			●			
	0.4488	--	5		GD05-1140	12	118	71	56	45			●			
	0.4488	--	3	Internal coolant	GD03C-1140	12	102	55	40	45			●			
	0.4488	--	5		GD05C-1140	12	118	71	56	45			●			
	0.4488	--	8		GD08C-1140	12	162	114	99	45			○			
11.45	0.4508	--	3	External coolant	GD03-1145	12	102	55	40	45		M12×1.25	●			
	0.4508	--	5		GD05-1145	12	118	71	56	45			●			
	0.4508	--	3	Internal coolant	GD03C-1145	12	102	55	40	45			●			
	0.4508	--	5		GD05C-1145	12	118	71	56	45			●			
11.5	0.4528	--	3	External coolant	GD03-1150	12	102	55	40	45		1/2-20UNF	●			
	0.4528	--	5		GD05-1150	12	118	71	56	45			●			

● Stock available ○ Make-to-order

Drill diameter d ₁ (mm)			Drilling depth (l/d)	Cooling mode	Shank type	Type	Basic dimension(mm)					Suitable for thread		Grade
mm	inch	Fraction					Shank diameter d ₂ (h ₆)	Overall length l ₁	Flute length l ₂	Recommended drilling depth l ₃	Shank length l ₄	cutting taps / tread milling cutters	forming taps	
11.5	0.4528	--	3	Internal coolant	Straight shank	GD03C-1150	12	102	55	40	45	1/2-20UNF		●
	0.4528	--	5			GD05C-1150	12	118	71	56	45			●
	0.4528	--	8			GD08C-1150	12	162	114	99	45			○
11.6	0.4567	--	3	External coolant		GD03-1160	12	102	55	40	45	1/2-13UNC		●
	0.4567	--	5			GD05-1160	12	118	71	56	45			●
	0.4567	--	3	Internal coolant		GD03C-1160	12	102	55	40	45			●
	0.4567	--	5			GD05C-1160	12	118	71	56	45			●
	0.4567	--	8			GD08C-1160	12	162	114	99	45			○
	0.4606	--	3			External coolant	GD03-1170	12	102	55	40			45
0.4606	--	5	GD05-1170	12			118	71	56	45	●			
11.7	0.4606	--	3	Internal coolant		GD03C-1170	12	102	55	40	45	●		
	0.4606	--	5			GD05C-1170	12	118	71	56	45	●		
	0.4606	--	8		GD08C-1170	12	162	114	99	45	○			
	0.4646	--	3		External coolant	GD03-1180	12	102	55	40	45	●		
0.4646	--	5	GD05-1180	12		118	71	56	45	●				
11.8	0.4646	--	3	Internal coolant	GD03C-1180	12	102	55	40	45	1/2-13UNC		●	
	0.4646	--	5		GD05C-1180	12	118	71	56	45			●	
	0.4646	--	8		GD08C-1180	12	162	114	99	45			○	
	0.4685	--	3		External coolant	GD03-1190	12	102	55	40			45	●
0.4685	--	5	GD05-1190	12		118	71	56	45	●				
11.9	0.4685	--	3	Internal coolant	GD03C-1190	12	102	55	40	45	1/2-13UNC		●	
	0.4685	--	5		GD05C-1190	12	118	71	56	45			●	
	0.4685	--	8		GD08C-1190	12	162	114	99	45			○	
	0.4724	--	3		External coolant	GD03-1200	12	102	55	40			45	M14×2
0.4724	--	5	GD05-1200	12		118	71	56	45	●				
0.4724	--	3	Internal coolant	GD03C-1200	12	102	55	40	45	●				
0.4724	--	5		GD05C-1200	12	118	71	56	45	●				
0.4724	--	8		GD08C-1200	12	162	114	99	45	○				
0.4764	--	3		External coolant	GD03-1210	14	107	60	43	45	1/2-20UNF		●	
0.4764	--	5	GD05-1210		14	124	77	60	45	●				
0.4764	--	3	Internal coolant	GD03C-1210	14	107	60	43	45	●				
0.4764	--	5		GD05C-1210	14	124	77	60	45	●				

Note: For drilling depth (l/d) of 8, namely GD08C series, tolerance of shank diameter is h₈.

● Stock available ○ Make-to-order

Applicable material table

◎ Very suitable ○ Suitable

Grade	Workpiece material										
	Mild steel HB ≤ 180	Carbon steel, Alloy steel	Pre-hardened steel, Hardened steel			Stainless steel	Cast iron	Nodular cast iron	Aluminum alloy	Copper alloy	Heat resistant alloy
			~40HRC	~50HRC	~60HRC						
KDG3013	○	◎	◎			○	◎	◎			○

GD series universal machining

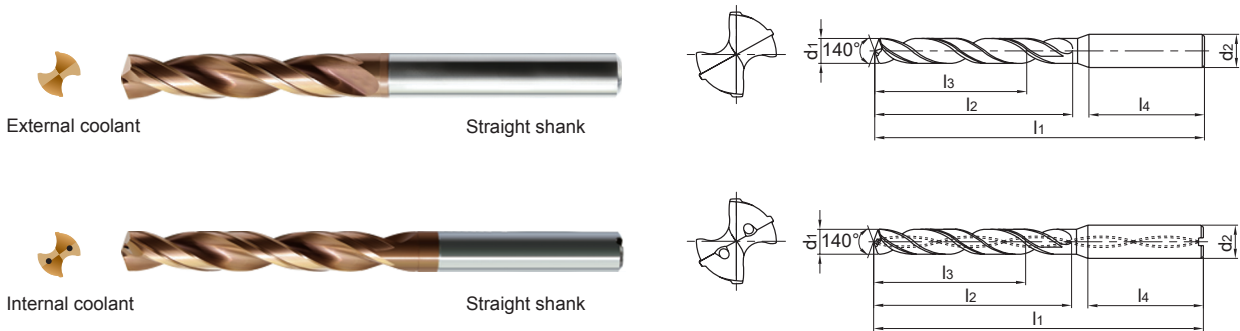

● Suitable for high efficiency drilling in a variety of materials e.g steel, stainless steel, cast iron.

Drill diameter d ₁ (m7)			Drilling depth (l/d)	Cooling mode	Shank type	Type	Basic dimension(mm)					Suitable for thread		Grade
mm	inch	Fraction					Shank diameter d ₂ (h6)	Overall length l ₁	Flute length l ₂	Recommended drilling depth l ₃	Shank length l ₄	cutting taps / tread milling cutters	forming taps	
12.2	0.4803	--	3	External coolant	Straight shank	GD03-1220	14	107	60	43	45	9/16-12UNC		●
	0.4803	--	5			GD05-1220	14	124	77	60	45			●
	0.4803	--	3	Internal coolant		GD03C-1220	14	107	60	43	45			●
	0.4803	--	5			GD05C-1220	14	124	77	60	45			●
12.25	0.4823	--	3	External coolant		GD03-1225	14	107	60	43	45			●
	0.4823	--	5			GD05-1225	14	124	77	60	45		●	
	0.4823	--	3	Internal coolant		GD03C-1225	14	107	60	43	45			●
	0.4823	--	5			GD05C-1225	14	124	77	60	45		●	
12.304	0.4844	31/64	3	External coolant		GD03-12304	14	107	60	43	45			●
	0.4844	31/64	5			GD05-12304	14	124	77	60	45		●	
	0.4844	31/64	3	Internal coolant		GD03C-12304	14	107	60	43	45			●
	0.4844	31/64	5			GD05C-12304	14	124	77	60	45		●	
12.5	0.4921	--	3	External coolant	GD03-1250	14	107	60	43	45	M14×1.5		●	
	0.4921	--	5		GD05-1250	14	124	77	60	45			●	
	0.4921	--	3	Internal coolant	GD03C-1250	14	107	60	43	45			●	
	0.4921	--	5		GD05C-1250	14	124	77	60	45			●	
	0.4921	--	8		GD08C-1250	14	178	133	116	45			○	
12.7	0.5000	1/2	3	External coolant	GD03-1270	14	107	60	43	45			●	
	0.5000	1/2	5		GD05-1270	14	124	77	60	45		●		
	0.5000	1/2	3	Internal coolant	GD03C-1270	14	107	60	43	45			●	
	0.5000	1/2	5		GD05C-1270	14	124	77	60	45		●		
	0.5000	1/2	8		GD08C-1270	14	178	133	116	45		○		
12.75	0.5020	--	3	External coolant	GD03-1275	14	107	60	43	45			●	
	0.5020	--	5		GD05-1275	14	124	77	60	45		●		
	0.5020	--	3	Internal coolant	GD03C-1275	14	107	60	43	45			●	
	0.5020	--	5		GD05C-1275	14	124	77	60	45		●		
12.8	0.5039	--	3	External coolant	GD03-1280	14	107	60	43	45			●	
	0.5039	--	5		GD05-1280	14	124	77	60	45		●		

● Stock available ○ Make-to-order

Drill diameter d ₁ (mm)			Drilling depth (l/d)	Cooling mode	Shank type	Type	Basic dimension(mm)					Suitable for thread		Grade		
mm	inch	Fraction					Shank diameter d ₂ (h ₆)	Overall length l ₁	Flute length l ₂	Recommended drilling depth l ₃	Shank length l ₄	cutting taps / tread milling cutters	forming taps			
12.8	0.5039	--	3	Internal coolant	Straight shank	GD03C-1280	14	107	60	43	45	9/16-18UNF		●		
	0.5039	--	5			GD05C-1280	14	124	77	60	45			●		
	0.5039	--	8			GD08C-1280	14	178	133	116	45			○		
12.9	0.5079	--	3	External coolant		GD03-1290	14	107	60	43	45			9/16-18UNF		●
	0.5079	--	5			GD05-1290	14	124	77	60	45					●
	0.5079	--	3	Internal coolant		GD03C-1290	14	107	60	43	45					●
	0.5079	--	5			GD05C-1290	14	124	77	60	45					●
13.0	0.5118	--	3	External coolant		GD03-1300	14	107	60	43	45			9/16-18UNF		●
	0.5118	--	5			GD05-1300	14	124	77	60	45					●
	0.5118	--	3	Internal coolant		GD03C-1300	14	107	60	43	45					●
	0.5118	--	5			GD05C-1300	14	124	77	60	45					●
	0.5118	--	8			GD08C-1300	14	178	133	116	45					○
13.1	0.5157	--	3	External coolant	GD03-1310	14	107	60	43	45	M14x2		●			
	0.5157	--	5		GD05-1310	14	124	77	60	45			●			
	0.5157	--	3	Internal coolant	GD03C-1310	14	107	60	43	45			●			
	0.5157	--	5		GD05C-1310	14	124	77	60	45			●			
13.35	0.5256	--	3	External coolant	GD03-1335	14	107	60	43	45	M14x1.5 9/16-12UNC		●			
	0.5256	--	5		GD05-1335	14	124	77	60	45			●			
	0.5256	--	3	Internal coolant	GD03C-1335	14	107	60	43	45			●			
	0.5256	--	5		GD05C-1335	14	124	77	60	45			●			
13.5	0.5315	--	3	External coolant	GD03-1350	14	107	60	43	45	5/8-11UNC		●			
	0.5315	--	5		GD05-1350	14	124	77	60	45			●			
	0.5315	--	3	Internal coolant	GD03C-1350	14	107	60	43	45			●			
	0.5315	--	5		GD05C-1350	14	124	77	60	45			●			
	0.5315	--	8		GD08C-1350	14	178	133	116	45			○			
13.65	0.5374	--	3	External coolant	GD03-1365	14	107	60	43	45	9/16-18UNF		●			
	0.5374	--	5		GD05-1365	14	124	77	60	45			●			
	0.5374	--	3	Internal coolant	GD03C-1365	14	107	60	43	45			●			
	0.5374	--	5		GD05C-1365	14	124	77	60	45			●			
13.8	0.5433	--	3	External coolant	GD03-1380	14	107	60	43	45			●			
	0.5433	--	5		GD05-1380	14	124	77	60	45			●			
	0.5433	--	3	Internal coolant	GD03C-1380	14	107	60	43	45			●			
	0.5433	--	5		GD05C-1380	14	124	77	60	45			●			

Note: For drilling depth (l/d) of 8 ,namely GD08C series, tolerance of shank diameter is h₈.

● Stock available ○ Make-to-order

Applicable material table

◎ Very suitable ○ Suitable

Grade	Workpiece material										
	Mild steel HB ≤ 180	Carbon steel, Alloy steel	Pre-hardened steel, Hardened steel			Stainless steel	Cast iron	Nodular cast iron	Aluminum alloy	Copper alloy	Heat resistant alloy
			~40HRC	~50HRC	~60HRC						
KDG3013	○	◎	◎			○	◎	◎			○

GD series universal machining

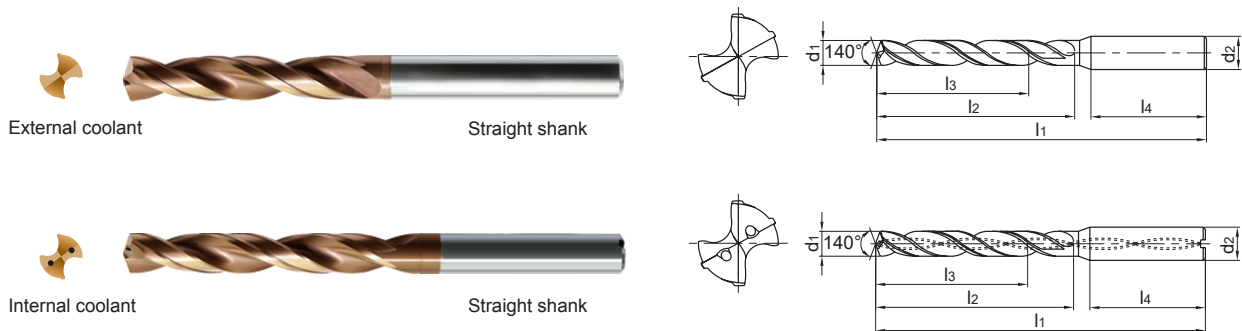

● Suitable for high efficiency drilling in a variety of materials e.g steel, stainless steel, cast iron.

Drill diameter d ₁ (m ₇)			Drilling depth (l/d)	Cooling mode	Shank type	Type	Basic dimension(mm)					Suitable for thread		Grade
mm	inch	Fraction					Shank diameter d ₂ (h ₆)	Overall length l ₁	Flute length l ₂	Recommended drilling depth l ₃	Shank length l ₄	cutting taps / tread milling cutters	forming taps	
14.0	0.5512	--	3	External coolant	Straight shank	GD03-1400	14	107	60	43	45	M16×2		●
	0.5512	--	5			GD05-1400	14	124	77	60	45			●
	0.5512	--	3	Internal coolant		GD03C-1400	14	107	60	43	45			●
	0.5512	--	5			GD05C-1400	14	124	77	60	45			●
	0.5512	--	8			GD08C-1400	14	178	133	116	45			○
14.25	0.5610	--	3	External coolant		GD03-1425	16	115	65	45	48		●	
	0.5610	--	5			GD05-1425	16	133	83	63	48		●	
	0.5610	--	3	Internal coolant		GD03C-1425	16	115	65	45	48		●	
	0.5610	--	5			GD05C-1425	16	133	83	63	48		●	
14.288	0.5625	9/16	3	External coolant		GD03-14288	16	115	65	45	48		●	
	0.5625	9/16	5		GD05-14288	16	133	83	63	48		●		
	0.5625	9/16	3	Internal coolant	GD03C-14288	16	115	65	45	48		●		
	0.5625	9/16	5		GD05C-14288	16	133	83	63	48		●		
14.3	0.5630	--	3	External coolant	GD03-1430	16	115	65	45	48		●		
	0.5630	--	5		GD05-1430	16	133	83	63	48		●		
	0.5630	--	3	Internal coolant	GD03C-1430	16	115	65	45	48		●		
	0.5630	--	5		GD05C-1430	16	133	83	63	48		●		
14.5	0.5709	--	3	External coolant	GD03-1450	16	115	65	45	48	M16×1.5 5/8-18UNF		●	
	0.5709	--	5		GD05-1450	16	133	83	63	48			●	
	0.5709	--	3	Internal coolant	GD03C-1450	16	115	65	45	48			●	
	0.5709	--	5		GD05C-1450	16	133	83	63	48			●	
	0.5709	--	8		GD08C-1450	16	204	152	132	48			○	
14.684	0.5781	37/64	3	External coolant	GD03-14684	16	115	65	45	48		●		
	0.5781	37/64	5		GD05-14684	16	133	83	63	48		●		
	0.5781	37/64	3	Internal coolant	GD03C-14684	16	115	65	45	48		●		
	0.5781	37/64	5		GD05C-14684	16	133	83	63	48		●		
14.75	0.5807	--	3	External coolant	GD03-1475	16	115	65	45	48		●		
	0.5807	--	5		GD05-1475	16	133	83	63	48		●		

● Stock available ○ Make-to-order

Drill diameter d ₁ (mm)			Drilling depth (l/d)	Cooling mode	Shank type	Type	Basic dimension(mm)					Suitable for thread		Grade
mm	inch	Fraction					Shank diameter d ₂ (h ₆)	Overall length l ₁	Flute length l ₂	Recommended drilling depth l ₃	Shank length l ₄	cutting taps / tread milling cutters	forming taps	
14.75	0.5807	--	3	Internal coolant	Straight shank	GD03C-1475	16	115	65	45	48	5/8-11UNC	●	
	0.5807	--	5			GD05C-1475	16	133	83	63	48		●	
14.8	0.5827	--	3	External coolant		GD03-1480	16	115	65	45	48		5/8-11UNC	●
	0.5827	--	5			GD05-1480	16	133	83	63	48			●
	0.5827	--	3	Internal coolant		GD03C-1480	16	115	65	45	48			●
	0.5827	--	5			GD05C-1480	16	133	83	63	48			●
15.0	0.5906	--	3	External coolant		GD08C-1480	16	204	152	132	48		5/8-11UNC	○
	0.5906	--	5			GD03-1500	16	115	65	45	48			●
	0.5906	--	3	Internal coolant		GD05-1500	16	133	83	63	48			●
	0.5906	--	5			GD03C-1500	16	115	65	45	48			●
15.1	0.5945	--	3	External coolant		GD05C-1500	16	133	83	63	48		M16×2	●
	0.5945	--	5			GD03-1510	16	115	65	45	48			●
	0.5945	--	3	Internal coolant	GD05-1510	16	133	83	63	48	●			
	0.5945	--	5		GD03C-1510	16	115	65	45	48	●			
15.25	0.6004	--	3	External coolant	GD05C-1510	16	133	83	63	48	5/8-18UNF	●		
	0.6004	--	5		GD03-1525	16	115	65	45	48		●		
	0.6004	--	3	Internal coolant	GD05-1525	16	133	83	63	48		●		
	0.6004	--	5		GD03C-1525	16	115	65	45	48		●		
15.35	0.6043	--	3	External coolant	GD05C-1525	16	133	83	63	48	M16×1.5	●		
	0.6043	--	5		GD03-1535	16	115	65	45	48		●		
	0.6043	--	3	Internal coolant	GD05-1535	16	133	83	63	48		●		
	0.6043	--	5		GD03C-1535	16	115	65	45	48		●		
15.5	0.6102	--	3	External coolant	GD05C-1535	16	133	83	63	48	M18×2.5	●		
	0.6102	--	5		GD03-1550	16	115	65	45	48		●		
	0.6102	--	3	Internal coolant	GD05-1550	16	133	83	63	48		●		
	0.6102	--	5		GD03C-1550	16	115	65	45	48		●		
	0.6102	--	8		GD05C-1550	16	133	83	63	48		●		
15.8	0.6220	--	3	External coolant	GD08C-1550	16	204	152	132	48	M18×2.5	○		
	0.6220	--	5		GD03-1580	16	115	65	45	48		●		
						GD05-1580	16	133	83	63	48		●	

Note: For drilling depth (l/d) of 8, namely GD08C series, tolerance of shank diameter is h₅.

● Stock available ○ Make-to-order



▶ Applicable material table

◎ Very suitable ○ Suitable

Grade	Workpiece material										
	Mild steel HB ≤ 180	Carbon steel, Alloy steel	Pre-hardened steel, Hardened steel			Stainless steel	Cast iron	Nodular cast iron	Aluminum alloy	Copper alloy	Heat resistant alloy
			~40HRC	~50HRC	~60HRC						
KDG3013	○	◎	◎			○	◎	◎			○

GD series universal machining

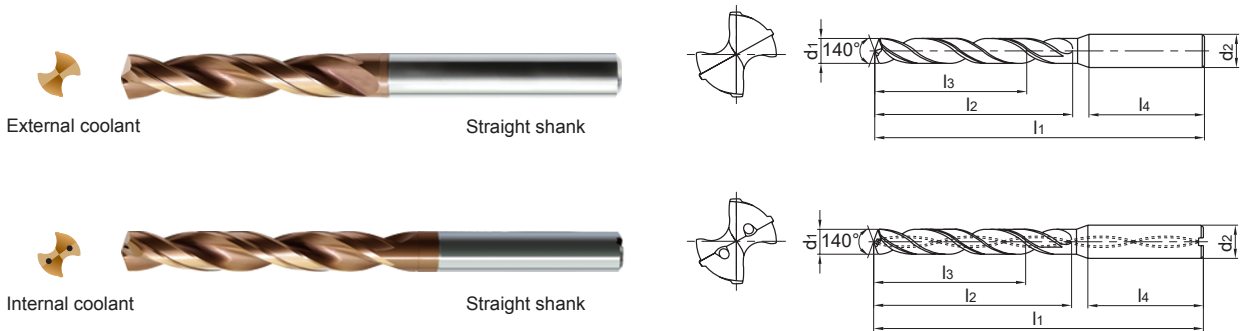

● Suitable for high efficiency drilling in a variety of materials e.g steel, stainless steel, cast iron.

Drill diameter d ₁ (m ₇)			Drilling depth (l/d)	Cooling mode	Shank type	Type	Basic dimension(mm)					Suitable for thread		Grade		
mm	inch	Fraction					Shank diameter	Overall length	Flute length	Recommended drilling depth	Shank length	cutting taps / tread milling cutters	forming taps		KDG3013	
									d ₂ (h ₆)	l ₁	l ₂	l ₃	l ₄			
15.8	0.6220	--	3	Internal coolant	Straight shank	GD03C-1580	16	115	65	45	48	M18×2		●		
	0.6220	--	5			GD05C-1580	16	133	83	63	48			●		
15.875	0.6250	5/8	3	External coolant		GD03-15875	16	115	65	45	48			●		
	0.6250	5/8	5			GD05-15875	16	133	83	63	48			●		
	0.6250	5/8	3	Internal coolant		GD03C-15875	16	115	65	45	48			●		
	0.6250	5/8	5			GD05C-15875	16	133	83	63	48			●		
16.0	0.6299	--	3	External coolant		GD03-1600	16	115	65	45	48			M18×2	●	
	0.6299	--	5			GD05-1600	16	133	83	63	48				●	
	0.6299	--	3	Internal coolant		GD03C-1600	16	115	65	45	48				●	
	0.6299	--	5			GD05C-1600	16	133	83	63	48				●	
	0.6299	--	8			GD08C-1600	16	204	152	132	48				○	
16.5	0.6496	--	3	External coolant		GD03-1650	18	123	73	51	48			3/4-10UNC	●	
	0.6496	--	5			GD05-1650	18	143	93	71	48				●	
	0.6496	--	3	Internal coolant		GD03C-1650	18	123	73	51	48				●	
	0.6496	--	5			GD05C-1650	18	143	93	71	48				●	
	0.6496	--	8			GD08C-1650	18	223	171	149	48				○	
	0.6594	--	3			External coolant	GD03-1675	18	123	73	51				48	
0.6594	--	5	GD05-1675	18			143	93	71	48	●					
0.6594	--	3	Internal coolant	GD03C-1675			18	123	73	51	48			●		
0.6594	--	5		GD05C-1675			18	143	93	71	48			●		
16.8	0.6614	--	3	External coolant		GD03-1680	18	123	73	51	48			M18×2.5	●	
	0.6614	--	5			GD05-1680	18	143	93	71	48				●	
	0.6614	--	3	Internal coolant		GD03C-1680	18	123	73	51	48				●	
	0.6614	--	5			GD05C-1680	18	143	93	71	48				●	
	0.6693	--	3		External coolant	GD03-1700	18	123	73	51	48		●			
0.6693	--	5	GD05-1700	18		143	93	71	48	●						
0.6693	--	3	Internal coolant	GD03C-1700		18	123	73	51	48	●					
0.6693	--	5		GD05C-1700		18	143	93	71	48	●					
17.0	0.6693	--	8	External coolant	GD08C-1700	18	223	171	149	48	○					

● Stock available ○ Make-to-order

Drill diameter d ₁ (mm)			Drilling depth (l/d)	Cooling mode	Shank type	Type	Basic dimension(mm)					Suitable for thread		Grade		
mm	inch	Fraction					Shank diameter d ₂ (h ₆)	Overall length l ₁	Flute length l ₂	Recommended drilling depth l ₃	Shank length l ₄	cutting taps / tread milling cutters	forming taps			
17.463	0.6875	11/16	3	External coolant	Straight shank	GD03-17463	18	123	73	51	48	M20×2.5 3/4-16UNF		●		
	0.6875	11/16	5			GD05-17463	18	143	93	71	48			●		
	0.6875	11/16	3	Internal coolant		GD03C-17463	18	123	73	51	48			●		
	0.6875	11/16	5			GD05C-17463	18	143	93	71	48			●		
17.5	0.6890	--	3	External coolant		GD03-1750	18	123	73	51	48			M20×2.5 3/4-16UNF		●
	0.6890	--	5			GD05-1750	18	143	93	71	48					●
	0.6890	--	3	Internal coolant		GD03C-1750	18	123	73	51	48					●
	0.6890	--	5			GD05C-1750	18	143	93	71	48					●
17.8	0.6890	--	8	External coolant	GD08C-1750	18	223	171	149	48	M20×2.5 3/4-16UNF		○			
	0.7008	--	3		Internal coolant	GD03-1780	18	123	73	51			48			●
	0.7008	--	5	Internal coolant		GD05-1780	18	143	93	71			48			●
	0.7008	--	3		Internal coolant	GD03C-1780	18	123	73	51			48			●
17.9	0.7008	--	5	Internal coolant		GD05C-1780	18	143	93	71			48	M20×2.5 3/4-16UNF		●
	0.7047	--	3		External coolant	GD03-1790	18	123	73	51			48			3/4-10UNC
	0.7047	--	5	Internal coolant		GD05-1790	18	143	93	71			48			
	0.7047	--	3		Internal coolant	GD03C-1790	18	123	73	51			48			
18.0	0.7047	--	5	Internal coolant		GD05C-1790	18	143	93	71	48	M20×2				
	0.7087	--	3		External coolant	GD03-1800	18	123	73	51	48					●
	0.7087	--	5	Internal coolant		GD05-1800	18	143	93	71	48					●
	0.7087	--	3		Internal coolant	GD03C-1800	18	123	73	51	48					●
18.3	0.7087	--	5	Internal coolant		GD05C-1800	18	143	93	71	48			M20×2		●
	0.7087	--	8		External coolant	GD08C-1800	18	223	171	149	48					○
	0.7205	--	3	External coolant		GD03-1830	20	131	79	55	50					3/4-16UNF
	0.7205	--	5		Internal coolant	GD05-1830	20	153	101	77	50					
0.7205	--	3	Internal coolant	GD03C-1830		20	131	79	55	50	●					
0.7205	--	5		Internal coolant	GD05C-1830	20	153	101	77	50	●					
18.5	0.7283	--	3		External coolant	GD03-1850	20	131	79	55	50	M20×2.5				●
	0.7283	--	5	Internal coolant		GD05-1850	20	153	101	77	50					●
	0.7283	--	3		Internal coolant	GD03C-1850	20	131	79	55	50			●		
	0.7283	--	5	Internal coolant		GD05C-1850	20	153	101	77	50			●		
18.8	0.7402	--	3		External coolant	GD03-1880	20	131	79	55	50			M20×2.5		●
	0.7402	--	5	GD05-1880		20	153	101	77	50	●					

Note: For drilling depth (l/d) of 8, namely GD08C series, tolerance of shank diameter is h₈.

● Stock available ○ Make-to-order

Applicable material table

○ Very suitable ○ Suitable

Grade	Workpiece material										
	Mild steel HB ≤ 180	Carbon steel, Alloy steel	Pre-hardened steel, Hardened steel			Stainless steel	Cast iron	Nodular cast iron	Aluminum alloy	Copper alloy	Heat resistant alloy
			~40HRC	~50HRC	~60HRC						
KDG3013	○	○	○			○	○	○			○

GD series universal machining

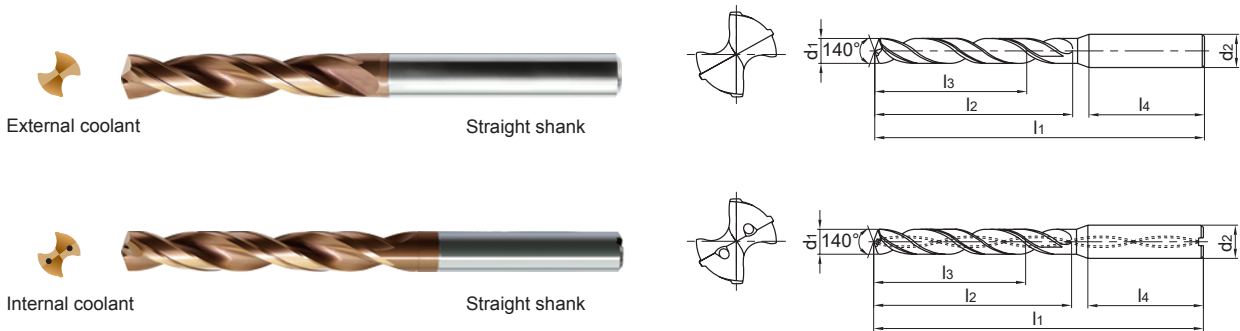

● Suitable for high efficiency drilling in a variety of materials e.g steel, stainless steel, cast iron.

Drill diameter d ₁ (m ₇)			Drilling depth (l/d)	Cooling mode	Shank type	Type	Basic dimension(mm)					Suitable for thread		Grade		
mm	inch	Fraction					Shank diameter	Overall length	Flute length	Recommended drilling depth	Shank length	cutting taps / tread milling cutters	forming taps		KDG3013	
									d ₂ (h ₆)	l ₁	l ₂	l ₃	l ₄			
18.8	0.7402	--	3	Internal coolant	Straight shank	GD03C-1880	20	131	79	55	50		M20×2.5	●		
	0.7402	--	5			GD05C-1880	20	153	101	77	50			●		
19.0	0.7480	--	3	External coolant		GD03-1900	20	131	79	55	50			●		
	0.7480	--	5			GD05-1900	20	153	101	77	50			●		
	0.7480	--	3	Internal coolant		GD03C-1900	20	131	79	55	50			●		
	0.7480	--	5			GD05C-1900	20	153	101	77	50			●		
19.05	0.7500	3/4	3	External coolant		GD03-1905	20	131	79	55	50			●		
	0.7500	3/4	5			GD05-1905	20	153	101	77	50			●		
	0.7500	3/4	3	Internal coolant		GD03C-1905	20	131	79	55	50			●		
	0.7500	3/4	5			GD05C-1905	20	153	101	77	50			●		
19.5	0.7677	--	3	External coolant		GD03-1950	20	131	79	55	50	M22×2.5 7/8-9UNC		●		
	0.7677	--	5			GD05-1950	20	153	101	77	50			●		
	0.7677	--	3	Internal coolant	GD03C-1950	20	131	79	55	50	●					
	0.7677	--	5		GD05C-1950	20	153	101	77	50	●					
19.8	0.7795	--	3	External coolant	GD03-1980	20	131	79	55	50			●			
	0.7795	--	5		GD05-1980	20	153	101	77	50			●			
	0.7795	--	3	Internal coolant	GD03C-1980	20	131	79	55	50			●			
	0.7795	--	5		GD05C-1980	20	153	101	77	50			●			
20.0	0.7874	--	3	External coolant	GD03-2000	20	131	79	55	50	M22×2		●			
	0.7874	--	5		GD05-2000	20	153	101	77	50			●			
	0.7874	--	3	Internal coolant	GD03C-2000	20	131	79	55	50			●			
	0.7874	--	5		GD05C-2000	20	153	101	77	50			●			

Note: For drilling depth (l/d) of 8, namely GD08C series, tolerance of shank diameter is h₈.

● Stock available ○ Make-to-order

Applicable material table

● Very suitable ○ Suitable

Grade	Workpiece material										
	Mild steel HB ≤ 180	Carbon steel, Alloy steel	Pre-hardened steel, Hardened steel			Stainless steel	Cast iron	Nodular cast iron	Aluminum alloy	Copper alloy	Heat resistant alloy
			~40HRC	~50HRC	~60HRC						
KDG3013	○	●	●			○	●	●			○